

VACON 100
AC DRIVES

INSTALLATION MANUAL

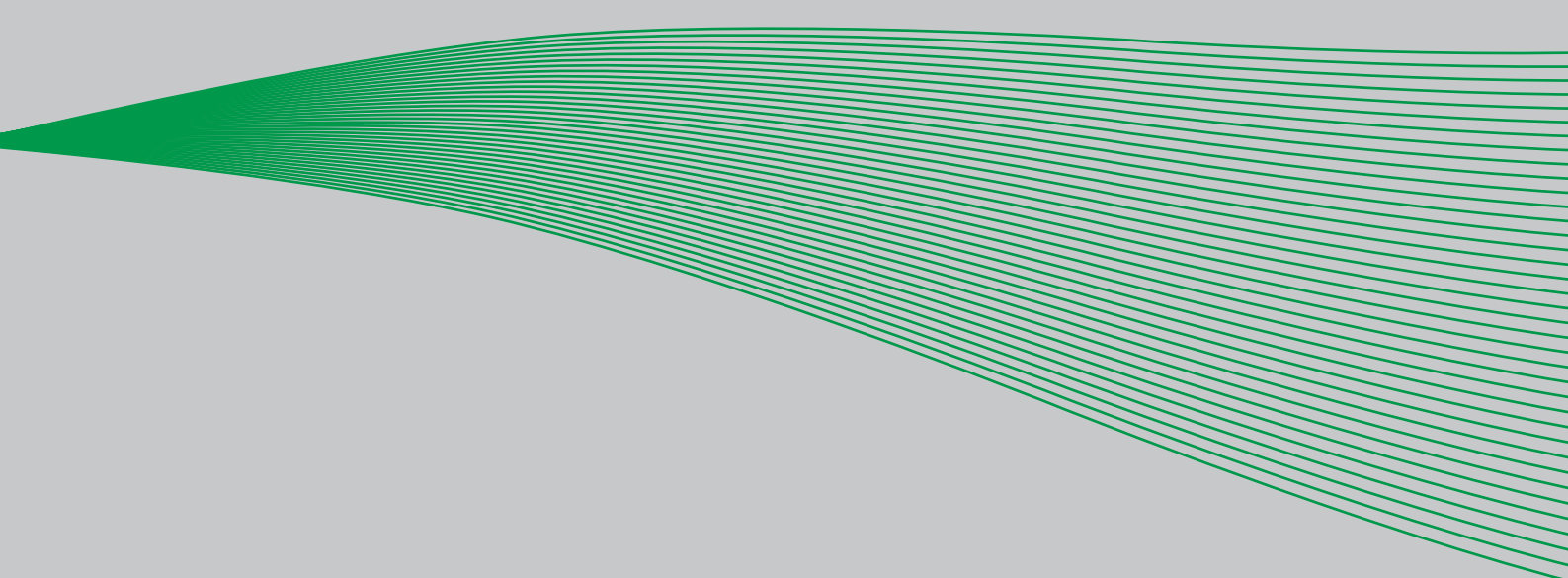

INDEX

Document: DPD00390D
Version release date: 27.1.11

1. Safety	4
1.1 Danger	4
1.2 Warnings	5
1.3 Earthing and earth fault protection	6
1.4 Electro-magnetic compatibility (EMC).....	7
2. Receipt of delivery	8
2.1 Type designation code.....	9
2.2 Unpacking and lifting the AC drive	10
2.2.1 Lifting frames MR8 and MR9	10
2.3 Accessories	11
2.3.1 Size MR4.....	11
2.3.2 Size MR5.....	11
2.3.3 Size MR6.....	12
2.3.4 Size MR7.....	12
2.3.5 Size MR8.....	12
2.3.6 Size MR9.....	13
2.4 'Product modified' sticker.....	13
3. Mounting.....	14
3.1 Dimensions.....	14
3.1.1 Wall mount	14
3.1.2 Flange mount	17
3.2 Cooling.....	21
4. Power cabling.....	24
4.1 UL standards on cabling	26
4.1.1 Cable dimensioning and selection.....	26
4.2 Brake resistor cables.....	30
4.3 Cable installation	31
4.3.1 Frames MR4 to MR7.....	31
4.3.2 Frames MR8 and MR9.....	38
4.4 Installation in corner-grounded network	47
5. Control unit	48
5.1 Control unit cabling.....	49
5.1.1 Control cable sizing.....	49
5.1.2 Control terminals and DIP switches.....	50
5.2 I/O cabling and Fieldbus connection.....	53
5.2.1 Prepare for use through ethernet	53
5.2.2 Prepare for use through RS485	55
5.3 Battery installation for Real Time Clock (RTC).....	59
5.4 Galvanic isolation barriers	60
6. Commissioning.....	62
6.1 Commissioning of the drive	63
6.2 Running the motor	63
6.2.1 Cable and motor insulation checks	64
6.3 Installation in it system.....	65
6.3.1 Frames MR4 to MR6.....	65
6.3.2 Frames MR7 and MR8.....	66

6.3.3	Frame MR9	67
6.4	Maintenance	69
7.	Technical data	71
7.1	AC drive power ratings.....	71
7.1.1	Mains voltage 208-240 V	71
7.1.2	Mains voltage 380-480 V	72
7.1.3	Definitions of overloadability	73
7.2	Vacon 100 - technical data	74
7.2.1	Technical information on control connections	76



EC DECLARATION OF CONFORMITY

We

Manufacturer's name: Vacon Oyj
Manufacturer's address: P.O.Box 25
Runsorintie 7
FIN-65381 VAASA
Finland

hereby declare that the product

Product name: Vacon 100 AC drive
Model designation: Vacon 100 3L 0003 2...3L 0310 2
Vacon 100 3L 0003 4...3L 0310 4

has been designed and manufactured in accordance with the following standards:

Safety: EN 61800-5-1 (2007)
EN 60204 -1 (2009) (as relevant)
EMC: EN 61800-3 (2004)
EN 61000-3-12

and conforms to the provisions of the Low Voltage Directive 2006/95/EC and the EMC Directive 2004/108/EC.

It is ensured through internal measures and quality control that the product conforms at all times to the requirements of the current Directive and the relevant standards.

In Vaasa, 7th of December, 2010

Vesa Laisi
President

The year the CE marking was affixed: 2009

1. SAFETY

This manual contains clearly marked cautions and warnings which are intended for your personal safety and to avoid any unintentional damage to the product or connected appliances.

Please read the information included in cautions and warnings carefully.

The cautions and warnings are marked as follows:



	= DANGEROUS VOLTAGE!
	= WARNING or CAUTION

Table 1. Warning signs

1.1 DANGER



The **components of the power unit of Vacon 100 are live** when the AC drive is connected to mains potential. Coming into contact with this voltage is **extremely dangerous** and may cause death or severe injury.



The **motor terminals U, V, W and the brake resistor terminals are live** when Vacon 100 is connected to mains, even if the motor is not running.



After disconnecting the AC drive from the mains, **wait** until the indicators on the keypad go out (if no keypad is attached see the indicators on the cover). Wait 5 more minutes before doing any work on the connections of Vacon100. Do not open the cover before this time has expired. After expiration of this time, use a measuring equipment to absolutely ensure that no voltage is present. **Always ensure absence of voltage before starting any electrical work!**



The control I/O-terminals are isolated from the mains potential. However, the **relay outputs and other I/O-terminals may have a dangerous control voltage** present even when Vacon 100 is disconnected from mains.



Before connecting the AC drive to mains make sure that the front and cable covers of Vacon 100 are closed.



During a coast stop (see the Application Manual), the motor is still generating voltage to the drive. Therefore, do not touch the components of the AC drive before the motor has completely stopped. Wait until the indicators on the keypad go out (if no keypad is attached see the indicators on the cover). Wait additional 5 minutes before starting any work on the drive.

1.2 WARNINGS



Vacon 100 AC drive is meant for **fixed installations only**.



Do not perform any measurements when the AC drive is connected to the mains.



The **touch current** of Vacon 100 AC drives exceeds 3.5mA AC. According to standard EN61800-5-1, a **reinforced protective ground connection** must be ensured. See chapter 1.3.



Corner grounding is allowed for the drive types with the ratings from 72 A to 310 A at 380...480 V supply and from 75 A to 310 A at 208...240 V supply. Remember to change the EMC level by removing the jumpers. See chapter 6.3.



If the AC drive is used as a part of a machine, the **machine manufacturer is responsible** for providing the machine with a **supply disconnecting device** (EN 60204-1).



Only **spare parts** delivered by Vacon can be used.



At power-up, power brake or fault reset **the motor will start immediately** if the start signal is active, unless the pulse control for Start/Stop logic has been selected. Furthermore, the I/O functionalities (including start inputs) may change if parameters, applications or software are changed. Disconnect, therefore, the motor if an unexpected start can cause danger.



The **motor starts automatically** after automatic fault reset if the autoreset function is activated. See the Application Manual for more detailed information.



Prior to measurements on the motor or the motor cable, disconnect the motor cable from the AC drive.



Do not touch the components on the circuit boards. Static voltage discharge may damage the components.



Check that the **EMC level** of the AC drive corresponds to the requirements of your supply network. See chapter 6.3.



In a domestic environment, this product may cause radio interference in which case supplementary mitigation measures may be required.

1.3 EARTHING AND EARTH FAULT PROTECTION



CAUTION!

The Vacon 100 AC drive must always be earthed with an earthing conductor connected to the earthing terminal marked with .

The touch current of Vacon 100 exceeds 3.5mA AC. According to EN61800-5-1, one or more of the following conditions for the associated protective circuit shall be satisfied:

A fixed connection and

- a) the **protective earthing conductor** shall have a cross-sectional area of at least 10 mm² Cu or 16 mm² Al.

or

- b) an automatic disconnection of the supply in case of discontinuity of the **protective earthing conductor**. See chapter 4.

or

- c) provision of an additional terminal for a second **protective earthing conductor** of the same cross-sectional area as the original **protective earthing conductor**.

Cross-sectional area of phase conductors (S) [mm ²]	Minimum cross-sectional area of the corresponding protective earthing conductor [mm ²]
$S \leq 16$	S
$16 < S \leq 35$	16
$35 < S$	$S/2$

The values above are valid only if the protective earthing conductor is made of the same metal as the phase conductors. If this is not so, the cross-sectional area of the protective earthing conductor shall be determined in a manner which produces a conductance equivalent to that which results from the application of this table.

Table 2. Protective earthing conductor cross-section

The cross-sectional area of every protective earthing conductor which does not form a part of the supply cable or cable enclosure shall, in any case, be not less than

- 2.5 mm² if mechanical protection is provided or
- 4 mm² if mechanical protection is not provided. For cord-connected equipment, provisions shall be made so that the protective earthing conductor in the cord shall, in the case of failure of the strain-relief mechanism, be the last conductor to be interrupted.

However, always follow the local regulations for the minimum size of the protective earthing conductor.

NOTE: Due to the high capacitive currents present in the AC drive, fault current protective switches may not function properly.



Do not perform any voltage withstand tests on any part of Vacon 100. There is a certain procedure according to which the tests shall be performed. Ignoring this procedure may result in damaged product.

1.4 ELECTRO-MAGNETIC COMPATIBILITY (EMC)

This equipment complies with IEC 61000-3-12 provided that the short-circuit power S_{SC} is greater than or equal to 120 at the interface point between the user's supply and the public system. It is the responsibility of the installer or user of the equipment to ensure, by consultation with the distribution network operator if necessary, that the equipment is connected only to a supply with a short-circuit power S_{SC} greater than or equal to 120.

2. RECEIPT OF DELIVERY

Check the correctness of delivery by comparing your order data to the drive information found on the package label. If the delivery does not correspond to your order, contact the supplier immediately. See chapter 2.1.

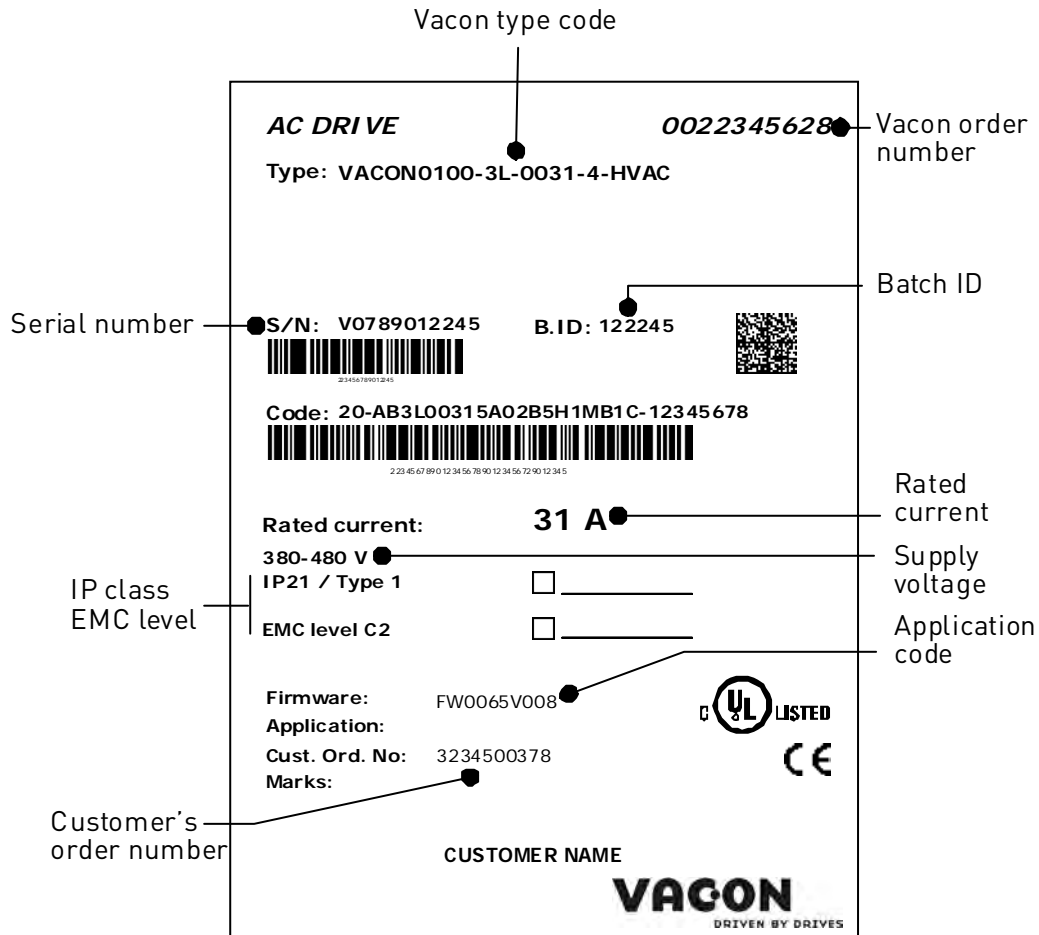

Figure 1. Vacon package label

2.1 TYPE DESIGNATION CODE

Vacon type designation code is formed of a nine-segment code and optional +codes. Each segment of the type designation code uniquely corresponds to the product and options you have ordered. The code is of the following format:

VACON0100-3L-0061-4-HVAC +xxxx +yyyy

VACON

This segment is common for all products.

0100

Product range:

0100 = Vacon 100

3L

Input/Function:

3L = Three-phase input

0061

Drive rating in ampere; e.g. 0061 = 61 A

4

Supply voltage:

2 = 208-240 V

4 = 380-480 V

HVAC

-IP21/Type 1

-EMC-level C2

-HVAC Application software (standard)

-HVAC documentation (standard)

-Graphical display panel

-Three relay outputs

+xxxx +yyyy

Additional codes.

Examples of additional codes:

+IP54

AC drive with IP protection class IP54

+SBF2

Two relays and a PTC input instead of three relays

2.2 UNPACKING AND LIFTING THE AC DRIVE

The weights of the AC drives vary greatly according to the size. You may need to use a piece of special lifting equipment to move the converter from its package. Note the weights of each individual frame size in Table 3 below.

Frame	Weight [kg]
MR4	6.0
MR5	10.0
MR6	20.0
MR7	37.5
MR8	66.0
MR9	108.0

Table 3. Frame weights

If you decide to use a piece of lifting equipment see picture below for recommendations to lift the drive.

2.2.1 LIFTING FRAMES MR8 AND MR9

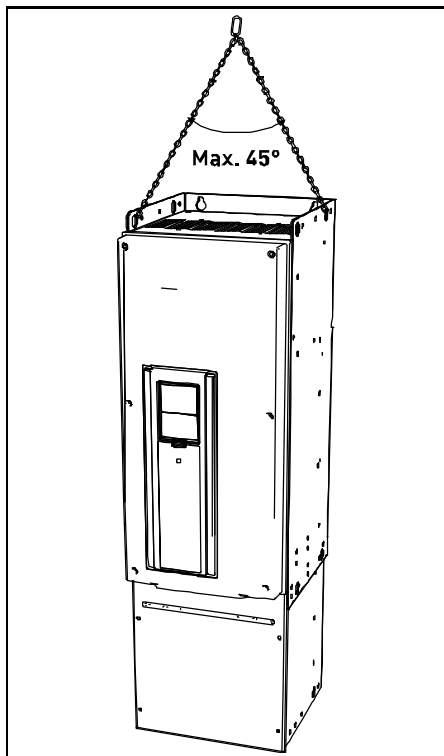

NOTE: First detach the drive from the pallet it has been bolted to.

NOTE: Place the lifting hooks symmetrically in at least two holes. The lifting device must be able to carry weight of the drive.

NOTE: The maximum allowed lifting angle is 45 degrees.

Figure 2. Lifting bigger frames

Vacon 100 AC drives have undergone scrupulous tests and quality checks at the factory before they are delivered to the customer. However, after unpacking the product, check that no signs of transport damages are to be found on the product and that the delivery is complete.

Should the drive have been damaged during the shipping, please contact primarily the cargo insurance company or the carrier.

2.3 ACCESSORIES

After having opened the transport package and lifted the converter out, check immediately that these various accessories were included in the delivery. The contents of the *accessories bag* differ by drive size and IP protections class:

2.3.1 SIZE MR4

Item	Quantity	Purpose
M4x16 screw	11	Screws for power cable clamps (6), control cable clamps (3), grounding clamps (2)
M4x8 screw	1	Screw for optional grounding
M5x12 screw	1	Screw for drive external grounding
Control cable grounding lamella	3	Control cable grounding
EMC cable clamps, size M25	3	Clamping power cables
Grounding clamp	2	Power cable grounding
'Product modified' label	1	Information about modifications
IP21: Cable grommet	3	Cable run-through sealing
IP54: Cable grommet	6	Cable run-through sealing

Table 4. Contents of accessories bag, MR4

2.3.2 SIZE MR5

Item	Quantity	Purpose
M4x16 screw	13	Screws for power cable clamps (6), control cable clamps (3), grounding clamps (4)
M4x8 screw	1	Screw for optional grounding
M5x12 screw	1	Screw for drive external grounding
Control cable grounding lamella	3	Control cable grounding
EMC cable clamps, size M25	1	Clamping brake resistor cable
EMC cable clamps, size M32	2	Clamping power cables
Grounding clamp	2	Power cable grounding
'Product modified' label	1	Information about modifications
IP21: Cable grommet, hole diameter 25.3 mm	1	Cable run-through sealing
IP54: Cable grommet, hole diameter 25.3 mm	4	Cable run-through sealing
Cable grommet, hole diameter 33.0 mm	2	Cable run-through sealing

Table 5. Contents of accessories bag, MR5

2.3.3 SIZE MR6

Item	Quantity	Purpose
M4x20 screw	10	Screws for power cable clamps (6) and grounding clamps (4)
M4x16 screw	3	Screws for control cable clamps
M4x8 screw	1	Screw for optional grounding
M5x12 screw	1	Screw for drive external grounding
Control cable grounding lamella	3	Control cable grounding
EMC cable clamps, size M32	1	Clamping brake resistor cable
EMC cable clamps, size M40	2	Clamping power cables
Grounding clamp	2	Power cable grounding
'Product modified' label	1	Information about modifications
Cable grommet, hole diameter 33.0 mm	1	Cable run-through sealing
Cable grommet, hole diameter 40.3 mm	2	Cable run-through sealing
IP54: Cable grommet, hole diameter 25.3 mm	3	Cable run-through sealing

Table 6. Contents of accessories bag, MR6

2.3.4 SIZE MR7

Item	Quantity	Purpose
M5x30 slotted nut	6	Nuts for power cable clamps
M4x16 screw	3	Screws for control cable clamps
M6x12 screw	1	Screw for drive external grounding
Control cable grounding lamella	3	Control cable grounding
EMC cable clamps, size M50	3	Clamping power cables
Grounding clamp	2	Power cable grounding
'Product modified' label	1	Information about modifications
Cable grommet, hole diameter 50.3 mm	3	Cable run-through sealing
IP54: Cable grommet, hole diameter 25.3 mm	3	Cable run-through sealing

Table 7. Contents of accessories bag, MR7

2.3.5 SIZE MR8

Item	Quantity	Purpose
M4x16 screw	3	Screws for control cable clamps
Control cable grounding lamella	3	Control cable grounding
Cable lugs KP34	3	Clamping power cables
Cable insulator	11	Avoiding contact between cables
Cable grommet, hole diameter 25.3 mm	4	Control cable run-through sealing

Table 8. Contents of accessories bag, MR8

2.3.6 SIZE MR9

Item	Quantity	Purpose
M4x16 screw	3	Screws for control cable clamps
Control cable grounding lamella	3	Control cable grounding
Cable lugs KP40	5	Clamping power cables
Cable insulator	10	Avoiding contact between cables
Cable grommet, hole diameter 25.3 mm	4	Control cable run-through sealing

Table 9. Contents of accessories bag, MR9

2.4 'PRODUCT MODIFIED' STICKER

In the Accessories bag included in the delivery you will find a silver *Product modified* sticker. The purpose of the sticker is to notify the service personnel about the modifications made in the AC drive. Attach the sticker on the side of the AC drive to avoid losing it. Should the AC drive be later modified mark the change on the sticker.

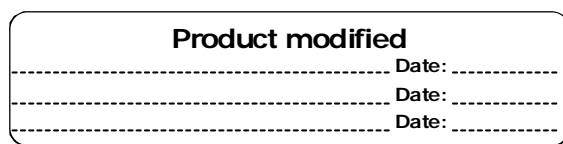

Figure 3. 'Product modified' sticker

3. MOUNTING

The AC drive must be mounted in vertical position on the wall or on the back plane of a cubicle. Ensure that the mounting plane is relatively even.

The AC drive shall be fixed with four screws (or bolts, depending on the unit size).

3.1 DIMENSIONS

3.1.1 WALL MOUNT

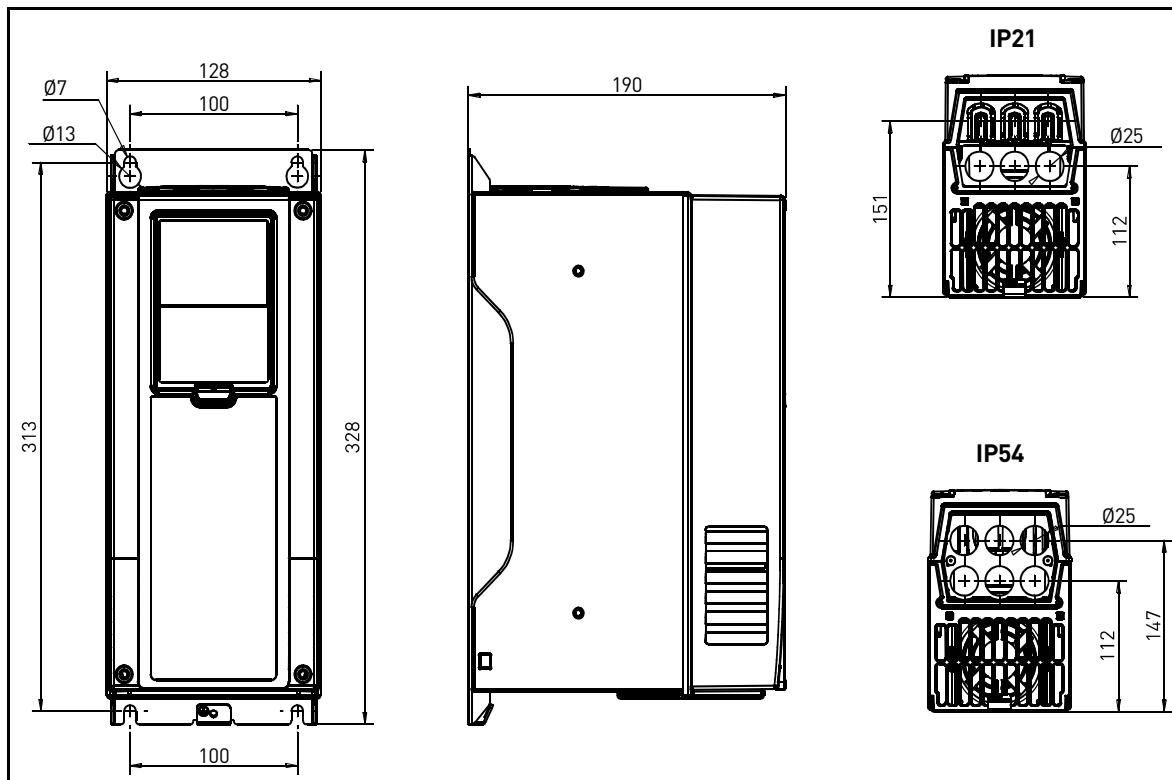

Figure 4. Vacon AC drive dimensions, MR4, wall mount

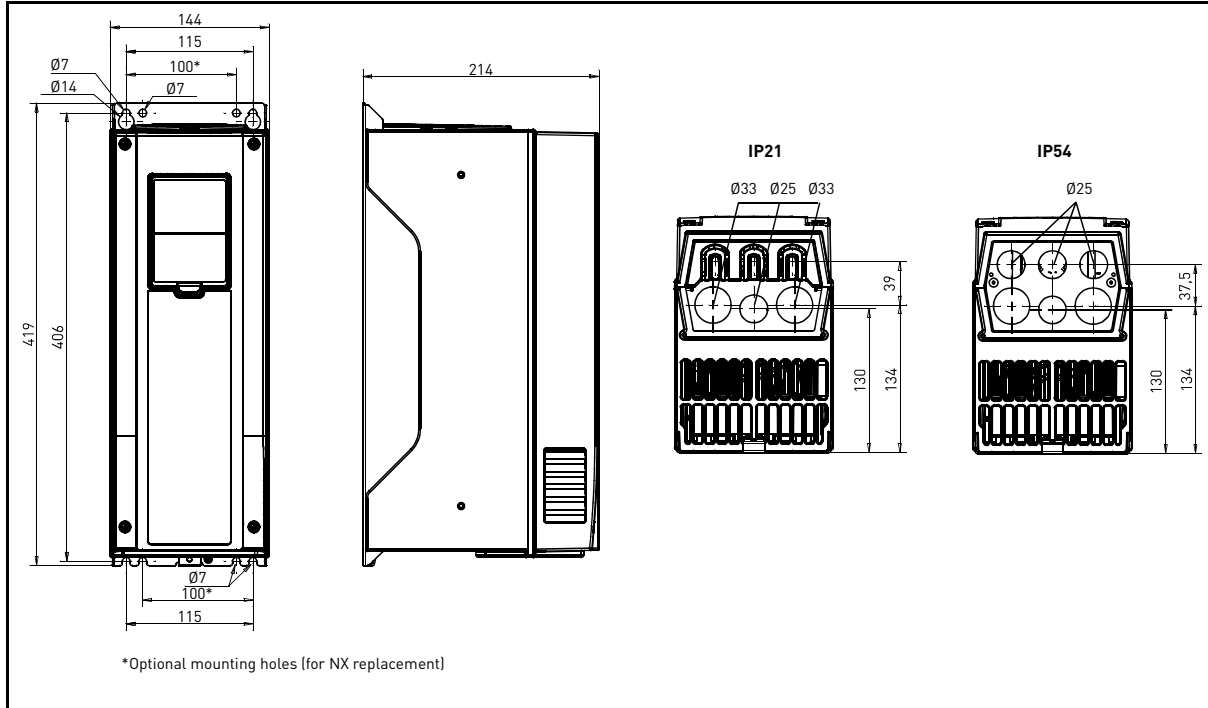

Figure 5. Vacon AC drive dimensions, MR5, wall mount

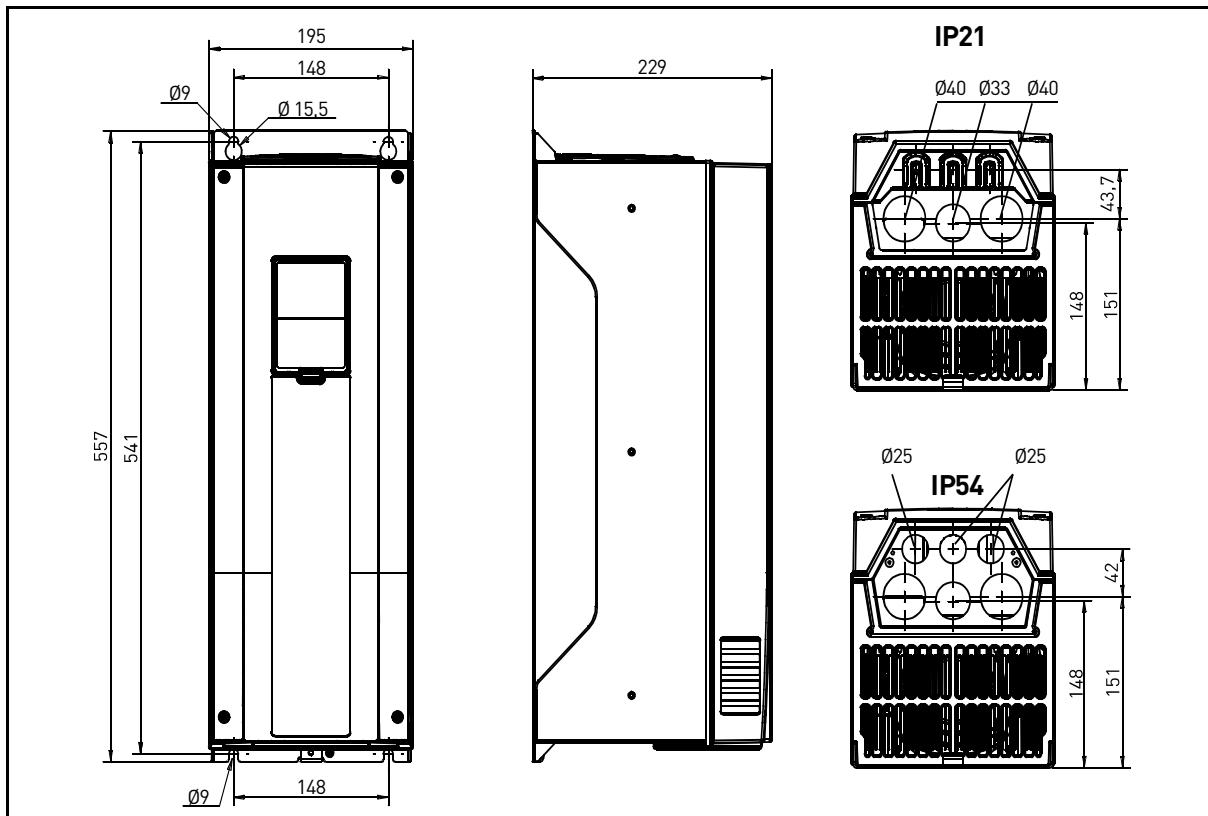

Figure 6. Vacon AC drive dimensions, MR6, wall mount

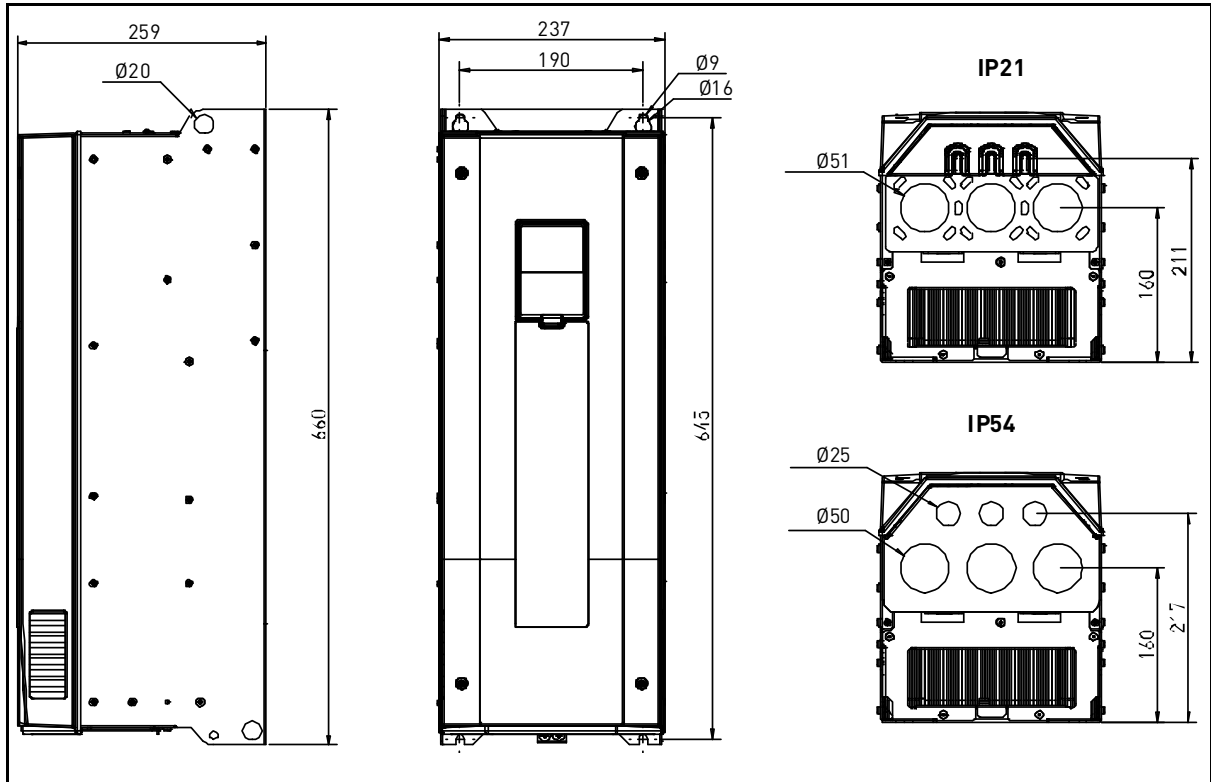

Figure 7. Vacon AC drive dimensions, MR7, wall mount

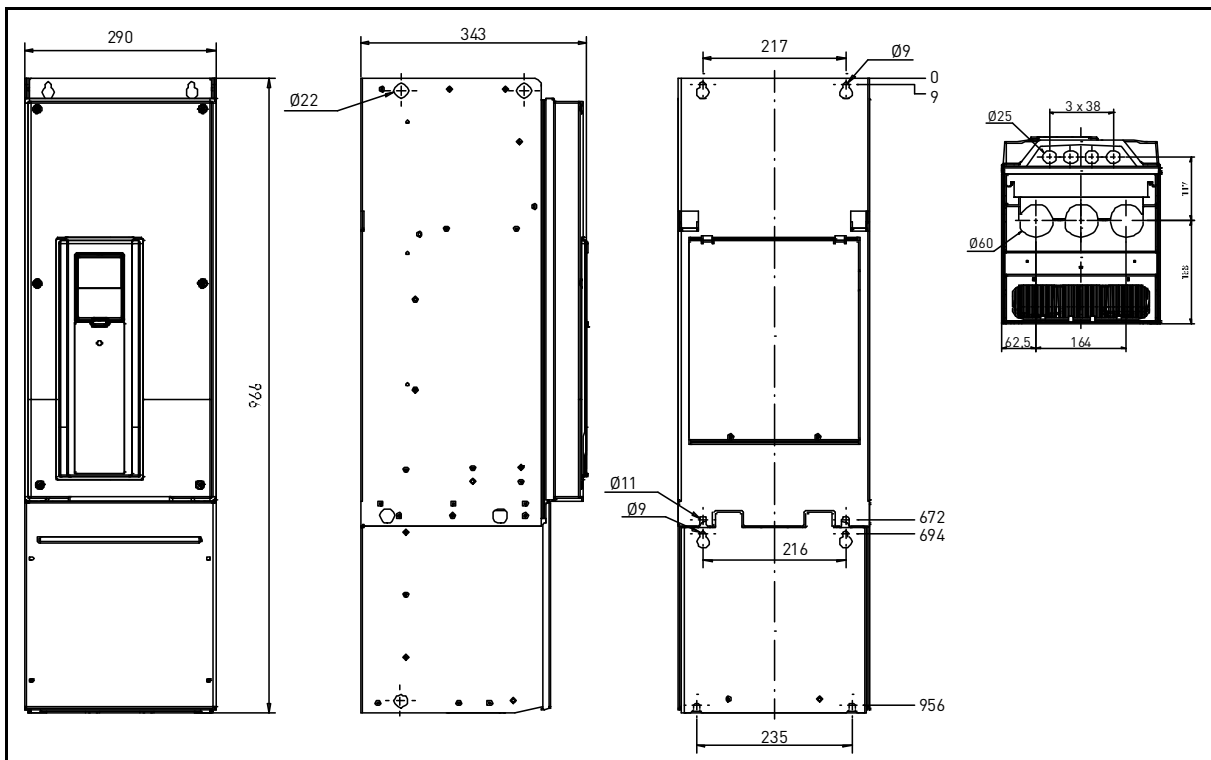

Figure 8. Vacon AC drive dimensions, MR8 IP21 and IP54

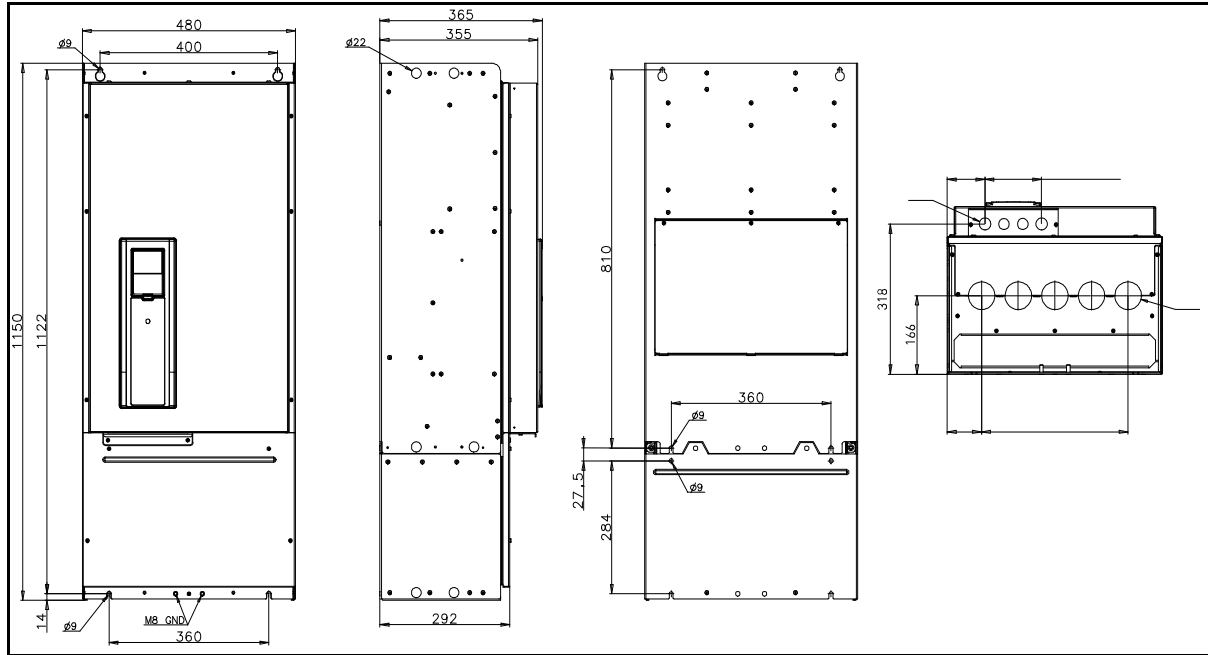

Figure 9. Vacon AC drive dimensions, MR9 IP21 and IP54

3.1.2 FLANGE MOUNT

The AC drive can also be recessed into the cabinet wall or similar surface. A special *flange mount option* is available for this purpose. For an example of a flange-mounted drive, see Figure 10. Note the IP classes of different sections in figure below.

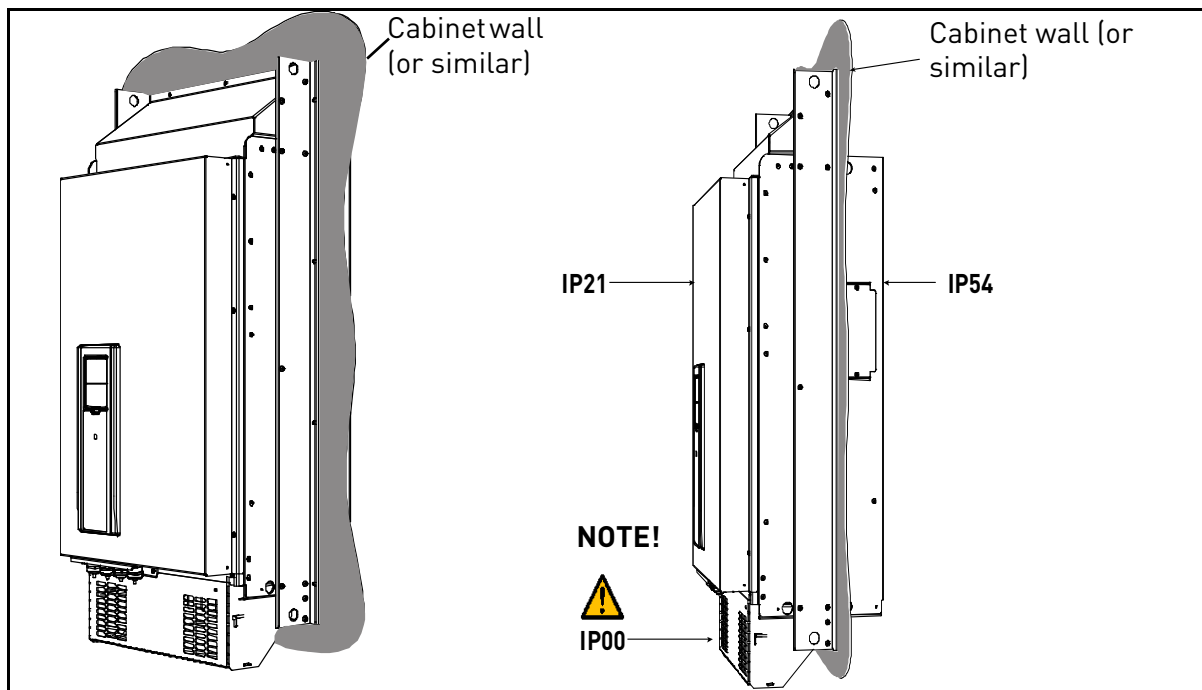

Figure 10. Example of flange mount (frame MR9)

3.1.2.1 FLANGE MOUNT - FRAMES MR4 TO MR6

Figure 11. presents the dimensions of the mounting opening and Figure 12. the depth dimensions of the drives with the flange mount option.

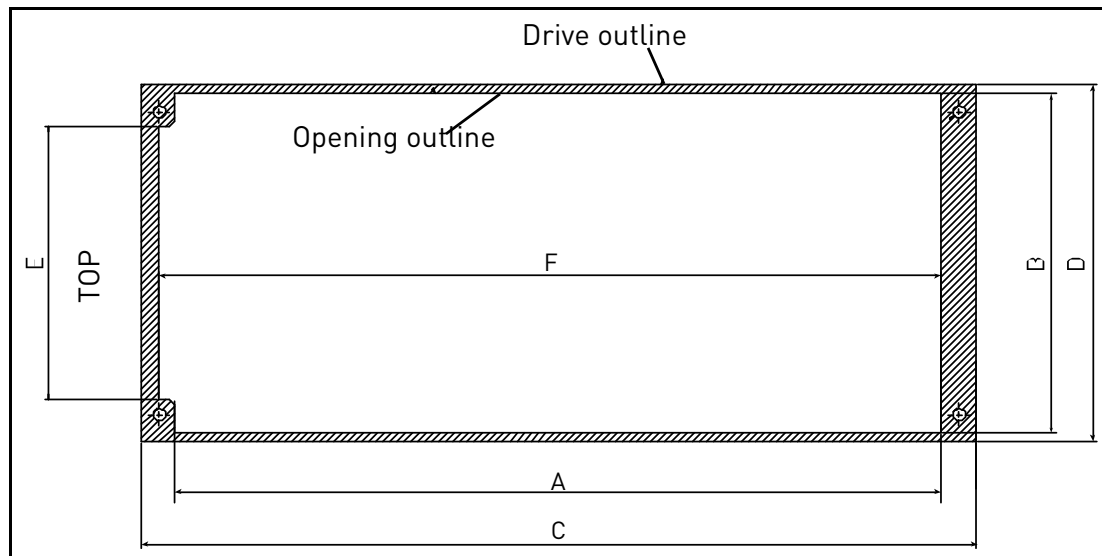

Figure 11. Flange mount cutout dimensions for MR4 to MR6

Frame	A	B	C	D	E	F
MR4	310	137	337	144	110	316
MR5	408	152	434	160	132	414
MR6	534	203	560	211	184	541

Table 10. Flange mount cutout dimensions for MR4 to MR6 [mm]

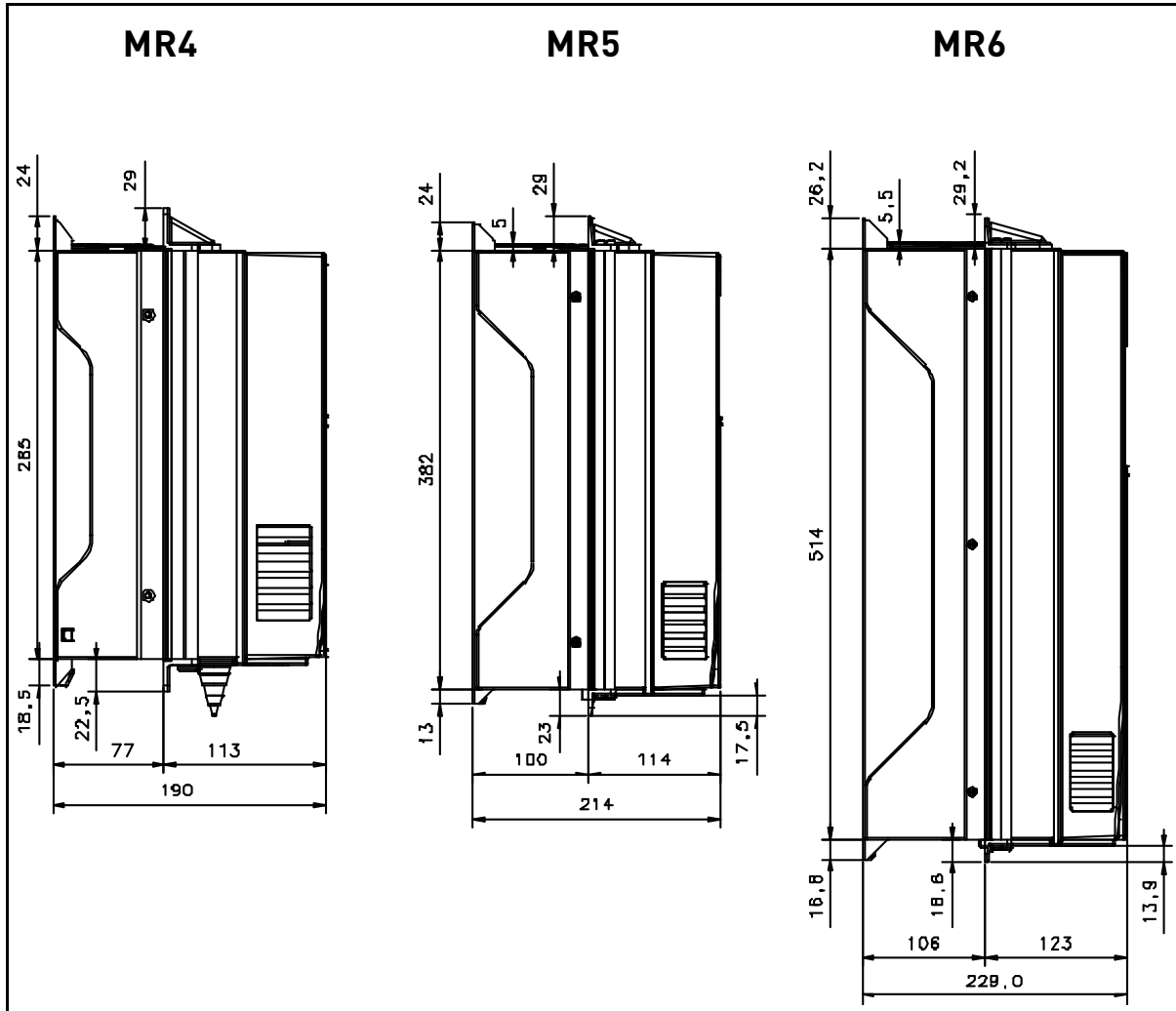

Figure 12. MR4 to MR6, flange mount, depth dimensions

3.1.2.2 FLANGE MOUNT MR7 TO MR9

Figure 13. presents the dimensions of the mounting opening and Figure 14. the dimensions of the drives with the flange mount option.

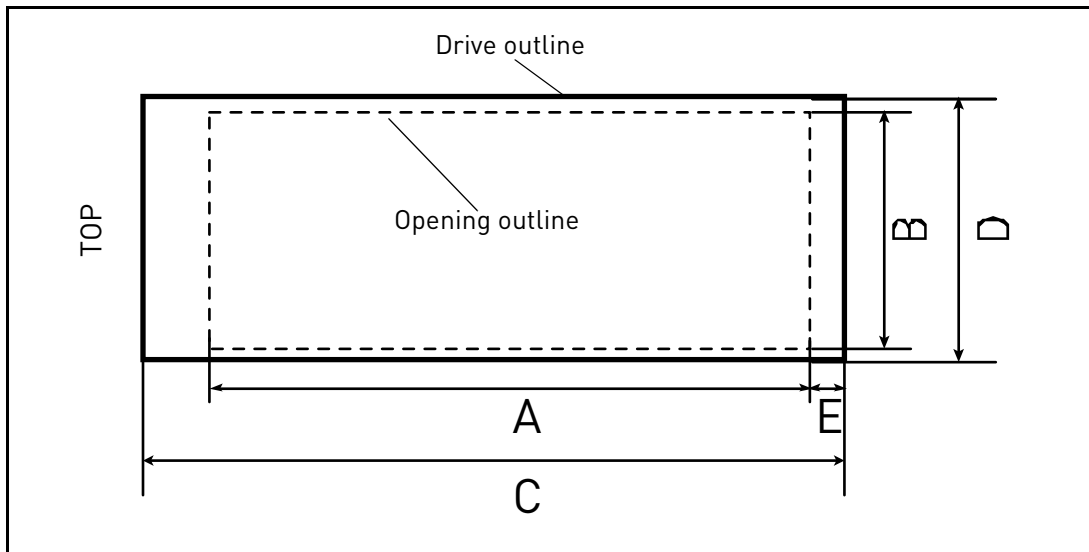

Figure 13. Flange mount cutout dimensions for MR7 to MR9

Frame	A	B	C	D	E
MR7	655	240	682	268	13.5
MR8	859	298	888	359	17
MR9	975	485	1050	530	54

Table 11. Flange mount cutout dimensions for MR7 to MR9

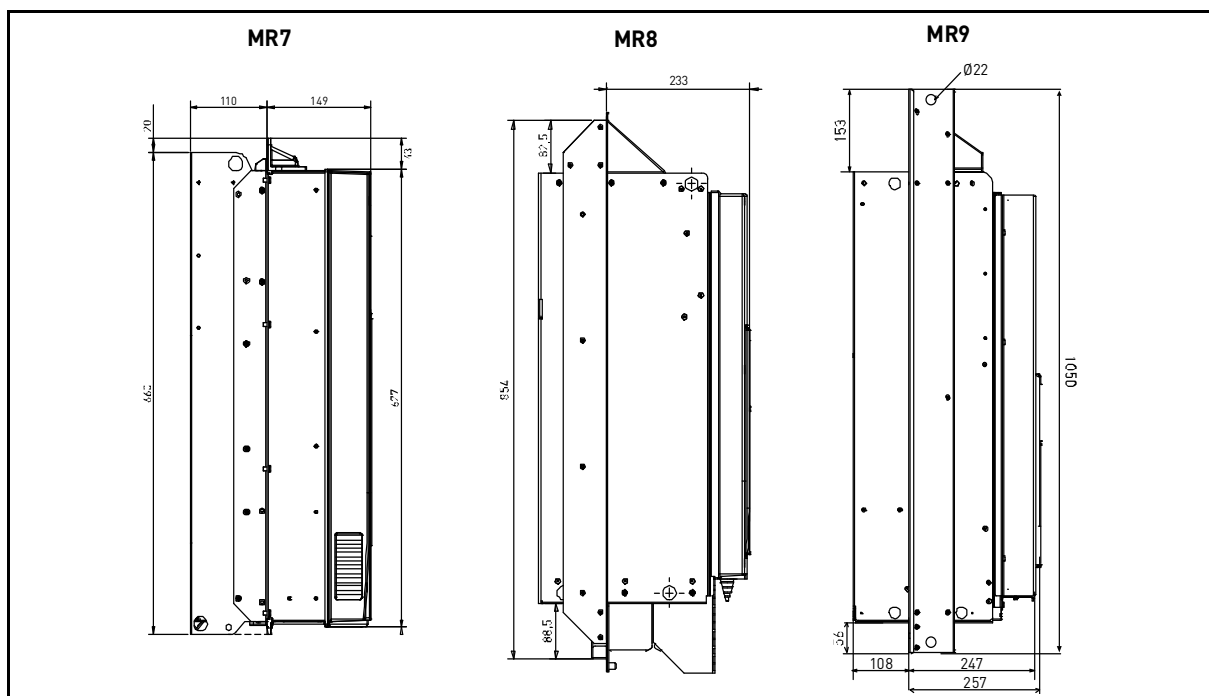
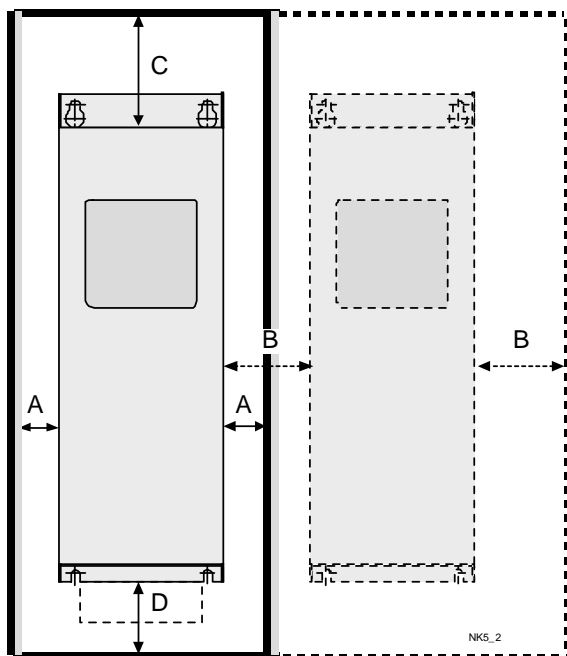

Figure 14. MR7 to MR9, flange mount, depth dimensions

3.2 COOLING

The AC drives produce heat in operation and are cooled down by air circulated by a fan. Enough free space shall therefore be left around the AC drive to ensure sufficient air circulation and cooling. Different acts of maintenance also require certain amount of free space.

Make sure that the temperature of the cooling air does not exceed the maximum ambient temperature of the converter.



Min clearance [mm]				
Type	A*	B*	C	D
MR4	20	20	100	50
MR5	20	20	120	60
MR6	20	20	160	80
MR7	20	20	250	100
MR8	20	20	300	150
MR9	20	20	350	200

*. Min clearances A and B for drives with IP54 enclosure is **0 mm**.

Table 12. Min. clearances around AC drive

Figure 15. Installation space

- A** = clearance around the freq. converter (see also B)
- B** = distance from one AC drive to another or distance to cabinet wall
- C** = free space above the AC drive
- D** = free space underneath the AC drive

Table 13. Required cooling air

Type	Cooling air required [m³/h]
MR4	45
MR5	75
MR6	190
MR7	185
MR8	335
MR9	621

Note that if several units are mounted **above** each other the required free space equals $C + D$ (see Figure 16.). Moreover, the outlet air used for cooling by the lower unit must be directed away from the air intake of the upper unit by means of e.g. a piece of metal plate fixed to cabinet wall between the drives as shown in Figure 16.

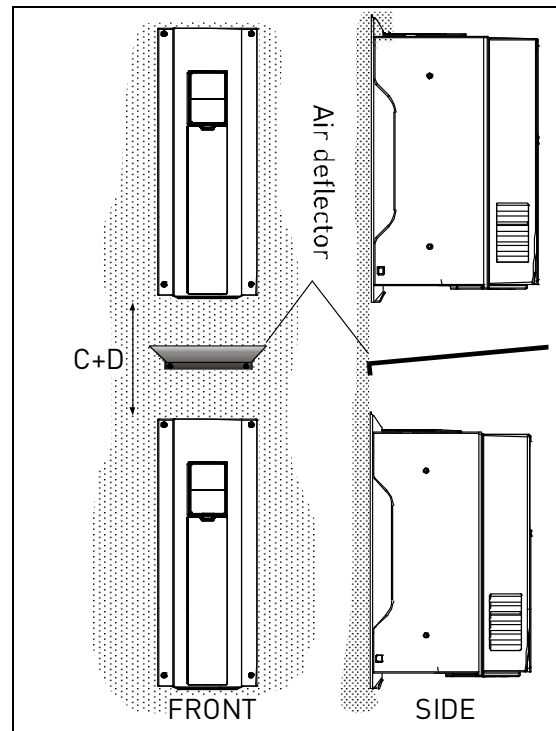

Figure 16. Installation space when drives are mounted on top of each other

4. POWER CABLING

The mains cables are connected to terminals L1, L2 and L3 and the motor cables to terminals marked with U, V and W. See principal connection diagram in Figure 17. See also Table 14 for the cable recommendations for different EMC levels.

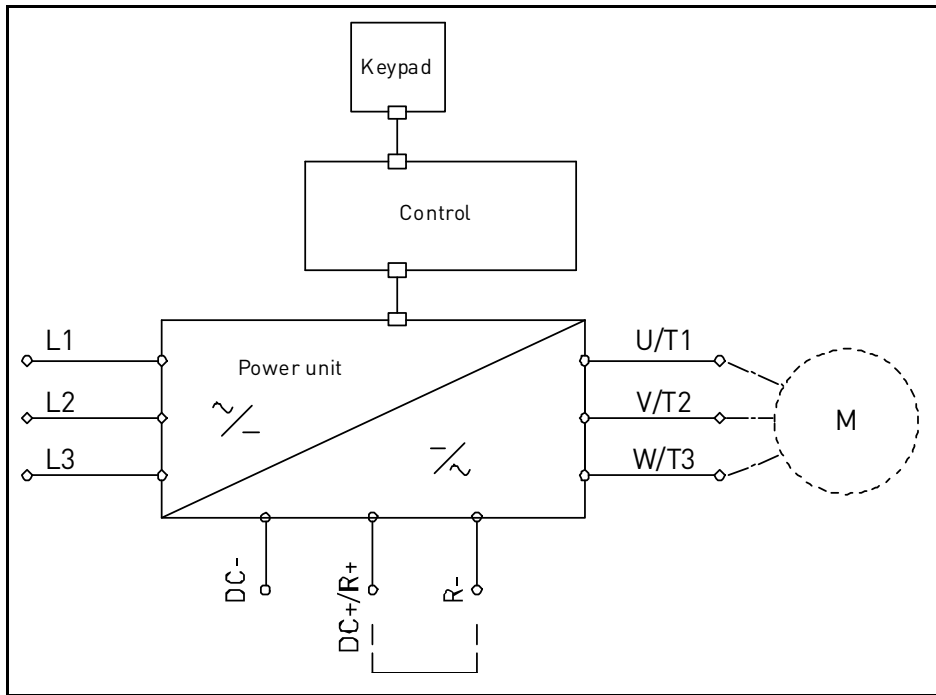

Figure 17. Principal connection diagram

Use cables with heat resistance of at least +70°C. The cables and the fuses must be dimensioned according to the AC drive nominal OUTPUT current which you can find on the rating plate.

Cable type	EMC levels		
	1 st environment	2nd environment	
	Category C2	Category C3	Level C4
Mains cable	1	1	1
Motor cable	3*	2	2
Control cable	4	4	4

Table 14. Cable types required to meet standards

- 1 = Power cable intended for fixed installation and the specific mains voltage. Shielded cable not required. (MCMK or similar recommended).
- 2 = Symmetrical power cable equipped with concentric protection wire and intended for the specific mains voltage. (MCMK or similar recommended). See Figure 18.

- 3 = Symmetrical power cable equipped with compact low-impedance shield and intended for the specific mains voltage. [MCCMK, EMCCK or similar recommended; Recommended cable transfer impedance (1...30MHz) max. 100mohm/m]. See Figure 18.
*360° earthing of the shield with cable glands in **motor end** needed for EMC level C2.
- 4 = Screened cable equipped with compact low-impedance shield (JAMAK, SAB/ÖZCuY-0 or similar).

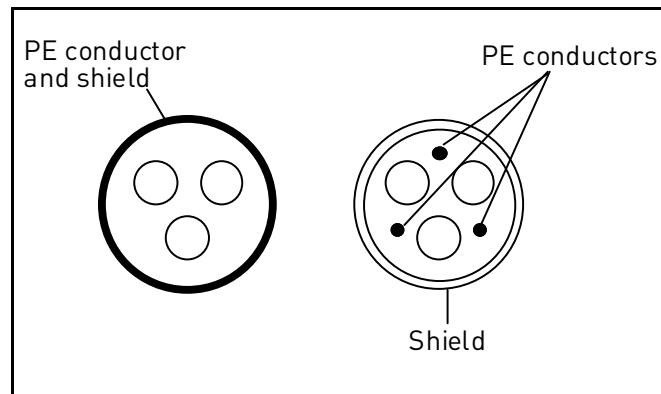

Figure 18.

NOTE: The EMC requirements are fulfilled at factory defaults of switching frequencies (all frames).

NOTE: If safety switch is connected the EMC protection shall be continuous over the whole cable installation.

4.1 UL STANDARDS ON CABLING

To meet the UL (Underwriters Laboratories) regulations, use a UL-approved copper cable with a minimum heat-resistance of +60/75°C. Use Class 1 wire only.

The units are suitable for use on a circuit capable of delivering not more than 100,000 rms symmetrical amperes, 600V maximum.

4.1.1 CABLE DIMENSIONING AND SELECTION

Table 15 shows the minimum dimensions of the Cu/Al-cables and the corresponding fuse sizes. Recommended fuse types are gG/gL.

These instructions apply only to cases with one motor and one cable connection from the AC drive to the motor. In any other case, ask the factory for more information.

4.1.1.1 CABLE AND FUSE SIZES, FRAMES MR4 TO MR6

The recommended fuse types are gG/gL (IEC 60269-1) or class T (UL & CSA). The fuse voltage rating should be selected according to the supply network. The final selection should be made according to local regulations, cable installation conditions and cable specification. Bigger fuses than what is recommended below shall not be used.

Check that the fuse operating time is less than 0.4 seconds. Operating time depends on used fuse type and impedance of the supply circuit. Consult the factory about faster fuses. Vacon offers recommendations also for high speed J (UL & CSA), aR (UL recognized, IEC 60269-4) and gS (IEC 60269-4) fuse ranges.

Frame	Type	I _L [A]	Fuse (gG/gL) [A]	Mains and motor cable Cu [mm ²]	Terminal cable size	
					Main terminal [mm ²]	Earth terminal [mm ²]
MR4	0003 2—0004 2	3.7—4.8	6	3*1.5+1.5	1—6 solid	1—6
	0003 4—0004 4	3.4—4.8			1—4 stranded	
	0006 2—0008 2	6.6—8.0	10	3*1.5+1.5	1—6 solid	1—6
	0005 4—0008 4	5.6—8.0			1—4 stranded	
	0011 2—0012 2	11.0—12.5	16	3*2.5+2.5	1—6 solid	1—6
	0009 4—0012 4	9.6—12.0			1—4 stranded	
MR5	0018 2	18.0	20	3*6+6	1—10 Cu	1—10
	0016 4	16.0				
	0024 2	24.0	25	3*6+6	1—10 Cu	1—10
	0023 4	23.0				
	0031 2	31.0	32	3*10+10	1—10 Cu	1—10
	0031 4	31.0				
MR6	0038 4	38.0	40	3*10+10	2.5—50 Cu/Al	2.5—35
	0048 2	48.0	50	3*16+16 (Cu)	2.5—50 Cu/Al	2.5—35
	0046 4	46.0		3*25+16 (Al)		
	0062 2	62.0	63	3*25+16 (Cu)	2.5—50 Cu/Al	2.5—35
	0061 4	61.0		3*35+10 (Al)		

Table 15. Cable and fuse sizes for Vacon 100 (MR4 to MR6)

The cable dimensioning is based on the criteria of the International Standard **IEC60364-5-52**:Cables must be PVC-isolated; Max ambient temperature +30°C, max temperature of cable surface +70°C; Use only cables with concentric copper shield; Max number of parallel cables is 9.

When using cables in parallel, **NOTE HOWEVER** that the requirements of both the cross-sectional area and the max number of cables must be observed.

For important information on the requirements of the earthing conductor, see chapter Earthing and earth fault protection of the standard.

For the correction factors for each temperature, see International Standard **IEC60364-5-52**.

4.1.1.2 CABLE AND FUSE SIZES, FRAMES MR7 TO MR9

The recommended fuse types are gG/gL (IEC 60269-1) or class T (UL & CSA). The fuse voltage rating should be selected according to the supply network. The final selection should be made according to local regulations, cable installation conditions and cable specification. Bigger fuses than what is recommended below shall not be used.

Check that the fuse operating time is less than 0.4 seconds. Operating time depends on used fuse type and impedance of the supply circuit. Consult the factory about faster fuses. Vacon offers recommendations also for high speed J (UL & CSA), aR (UL recognized, IEC 60269-4) and gS (IEC 60269-4) fuse ranges.

Frame	Type	I_L [A]	Fuse (gG/gL) [A]	Mains and motor cable Cu [mm ²]	Terminal cable size	
					Main terminal	Earth terminal
MR7	0075 2 0072 4	75,0 72,0	80	3*35+16 (Cu) 3*50+16 (Al)	6-70 mm ² Cu/Al	6-70 mm ²
	0088 2 0087 4	88,0 87,0	100	3*35+16 (Cu) 3*70+21 (Al)	6-70 mm ² Cu/Al	6-70 mm ²
	0105 2 0105 4	105,0	125	3*50+25 (Cu) 3*70+21 (Al)	6-70 mm ² Cu/Al	6-70 mm ²
	0140 2 0140 4	140,0	160	3*70+35 (Cu) 3*95+29 (Al)	Bolt size M8	Bolt size M8
MR8	0170 2 0170 4	170,0	200	3*95+50 (Cu) 3*150+41 (Al)	Bolt size M8	Bolt size M8
	0205 2 0205 4	205,0	250	3*120+70 (Cu) 3*185+57 (Al)	Bolt size M8	Bolt size M8
	0261 2 0261 4	261,0	315	3*185+95 (Cu) 2*3*120+41 (Al)	Bolt size M8	Bolt size M8
MR9	0310 2 0310 4	310,0	350	2*3*95+50 (Cu) 2*3*120+41 (Al)	Bolt size M8	Bolt size M8

Table 16. Cable and fuse sizes for Vacon 100

The cable dimensioning is based on the criteria of the International Standard **IEC60364-5-52**:Cables must be PVC-isolated; Max ambient temperature +30°C, max temperature of cable surface +70°C; Use only cables with concentric copper shield; Max number of parallel cables is 9.

When using cables in parallel, **NOTE HOWEVER** that the requirements of both the cross-sectional area and the max number of cables must be observed.

For important information on the requirements of the earthing conductor, see chapter Earthing and earth fault protection of the standard.

For the correction factors for each temperature, see International Standard **IEC60364-5-52**.

4.1.1.3 CABLE AND FUSE SIZES, FRAMES MR4 TO MR6, NORTH AMERICA

The recommended fuse types are gG/gL (IEC 60269-1) or class T (UL & CSA). The fuse voltage rating should be selected according to the supply network. The final selection should be made according to local regulations, cable installation conditions and cable specification. Bigger fuses than what is recommended below shall not be used.

Check that the fuse operating time is less than 0.4 seconds. Operating time depends on used fuse type and impedance of the supply circuit. Consult the factory about faster fuses. Vacon offers recommendations also for high speed J (UL & CSA), aR (UL recognized, IEC 60269-4) and gS (IEC 60269-4) fuse ranges.

Frame	Type	I _L [A]	Fuse (class T) [A]	Mains, motor and ground cable Cu	Terminal cable size	
					Main terminal	Earth terminal
MR4	0003 2 0003 4	3,7 3.4	6	AWG14	AWG24-AWG10	AWG17-AWG10
	0004 2 0004 4	4.8	6	AWG14	AWG24-AWG10	AWG17-AWG10
	0006 2 0005 4	6.6 5.6	10	AWG14	AWG24-AWG10	AWG17-AWG10
	0008 2 0008 4	8.0	10	AWG14	AWG24-AWG10	AWG17-AWG10
	0011 2 0009 4	11.0 9.6	15	AWG14	AWG24-AWG10	AWG17-AWG10
	0012 2 0012 4	12.5 12.0	20	AWG14	AWG24-AWG10	AWG17-AWG10
MR5	0018 2 0016 4	18.0 16.0	25	AWG10	AWG20-AWG5	AWG17-AWG8
	0024 2 0023 4	24.0 23.0	30	AWG10	AWG20-AWG5	AWG17-AWG8
	0031 2 0031 4	31.0	40	AWG8	AWG20-AWG5	AWG17-AWG8
MR6	0038 4	38.0	50	AWG4	AWG13-AWG0	AWG13-AWG2
	0048 2 0046 4	48.0 46.0	60	AWG4	AWG13-AWG0	AWG13-AWG2
	0062 2 0061 4*	62.0 61.0	80	AWG4	AWG13-AWG0	AWG13-AWG2

*. The 460V models require 90-degree wire to meet UL regulations

Table 17. Cable and fuse sizes for Vacon 100 (MR4 to MR6)

The cable dimensioning is based on the criteria of the Underwriters' Laboratories UL508C: Cables must be PVC-isolated; Max ambient temperature +30°C, max temperature of cable surface +70°C; Use only cables with concentric copper shield; Max number of parallel cables is 9.

When using cables in parallel, **NOTE HOWEVER** that the requirements of both the cross-sectional area and the max number of cables must be observed.

For important information on the requirements of the earthing conductor, see standard Underwriters' Laboratories UL508C.

For the correction factors for each temperature, see the instructions of standard Underwriters' Laboratories UL508C.

4.1.1.4 CABLE AND FUSE SIZES, FRAMES MR7 TO MR9, NORTH AMERICA

The recommended fuse types are gG/gL (IEC 60269-1) or class T (UL & CSA). The fuse voltage rating should be selected according to the supply network. The final selection should be made according to local regulations, cable installation conditions and cable specification. Bigger fuses than what is recommended below shall not be used.

Check that the fuse operating time is less than 0.4 seconds. Operating time depends on used fuse type and impedance of the supply circuit. Consult the factory about faster fuses. Vacon offers recommendations also for high speed J (UL & CSA), aR (UL recognized, IEC 60269-4) and gS (IEC 60269-4) fuse ranges.

Frame	Type	I _L [A]	Fuse (class T) [A]	Mains, motor and ground cable Cu	Terminal cable size	
					Main terminal	Earth terminal
MR7	0075 2 0072 4	75,0 72,0	100	AWG2	AWG9-AWG2/0	AWG9-AWG2/0
	0088 2 0087 4	88,0 87,0	110	AWG1	AWG9-AWG2/0	AWG9-AWG2/0
	0105 2 0105 4	105,0	150	AWG1/0	AWG9-AWG2/0	AWG9-AWG2/0
MR8	0140 2 0140 4	140,0	200	AWG3/0	AWG1-350 kcmil	AWG1-350 kcmil
	0170 2 0170 4	170,0	225	250 kcmil	AWG1-350 kcmil	AWG1-350 kcmil
	0205 2 0205 4	205,0	250	350 kcmil	AWG1-350 kcmil	AWG1-350 kcmil
MR9	0261 2 0261 4	261,0	350	2*250 kcmil	AWG1-350 kcmil	AWG1-350 kcmil
	0310 2 0310 4	310,0	400	2*350 kcmil	AWG1-350 kcmil	AWG1-350 kcmil

Table 18. Cable and fuse sizes for Vacon 100 (MR7 to MR9)

The cable dimensioning is based on the criteria of the Underwriters' Laboratories UL508C: Cables must be PVC-isolated; Max ambient temperature +30°C, max temperature of cable surface +70°C; Use only cables with concentric copper shield; Max number of parallel cables is 9.

When using cables in parallel, **NOTE HOWEVER** that the requirements of both the cross-sectional area and the max number of cables must be observed.

For important information on the requirements of the earthing conductor, see standard Underwriters' Laboratories UL508C.

For the correction factors for each temperature, see the instructions of standard Underwriters' Laboratories UL508C.

4.2 BRAKE RESISTOR CABLES

Vacon AC drives are equipped with terminals for an optional external brake resistor. These terminals are marked with **R+** and **R-** (MR4-MR6) or **DC+/R+** and **R-** (MR7 and bigger).

4.3 CABLE INSTALLATION

- Before starting, check that none of the components of the AC drive is live. Read carefully the warnings in chapter 1.
- Place the motor cables sufficiently far from other cables
- Avoid placing the motor cables in long parallel lines with other cables.
- If the motor cables run in parallel with other cables note the minimum distances between the motor cables and other cables given in table below.

Distance between cables, [m]	Shielded cable, [m]
0.3	≤ 50
1.0	≤ 200

- The given distances also apply between the motor cables and signal cables of other systems.
- The **maximum lengths of motor cables (shielded)** are **100 m** (MR4), **150 m** (MR5 and MR6) and **200 m** (MR7 to MR9).
- The motor cables should cross other cables at an angle of 90 degrees.
- If cable insulation checks are needed, see chapter Cable and motor insulation checks.

Start the cable installation according to the instructions below:

4.3.1 FRAMES MR4 TO MR7

1	Strip the motor and mains cables as advised below.
---	--

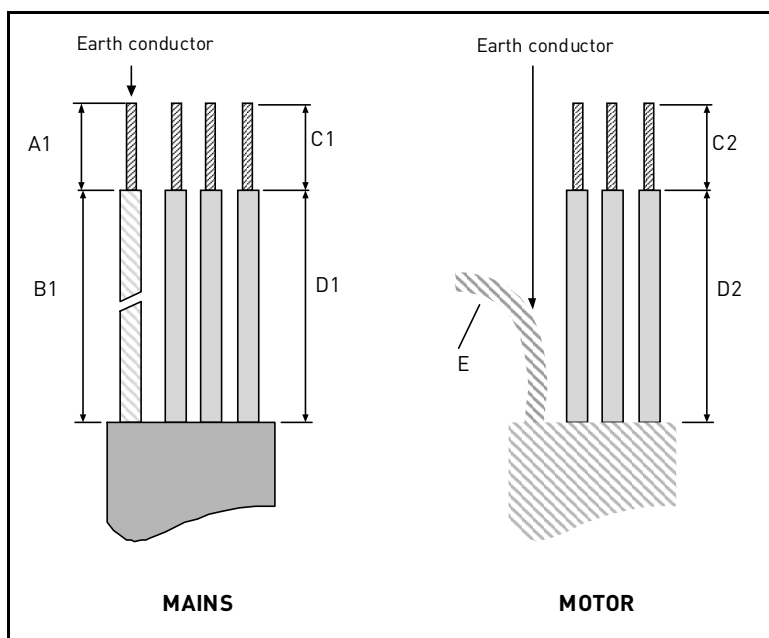

Figure 19. Stripping of cables

Frame	A1	B1	C1	D1	C2	D2	E
MR4	15	35	10	20	7	35	Leave as short as possible
MR5	20	40	10	30	10	40	
MR6	20	90	15	60	15	60	
MR7	20	80	20	80	20	80	

Table 19. Cables stripping lengths [mm]

2

Open the cover of the AC drive.

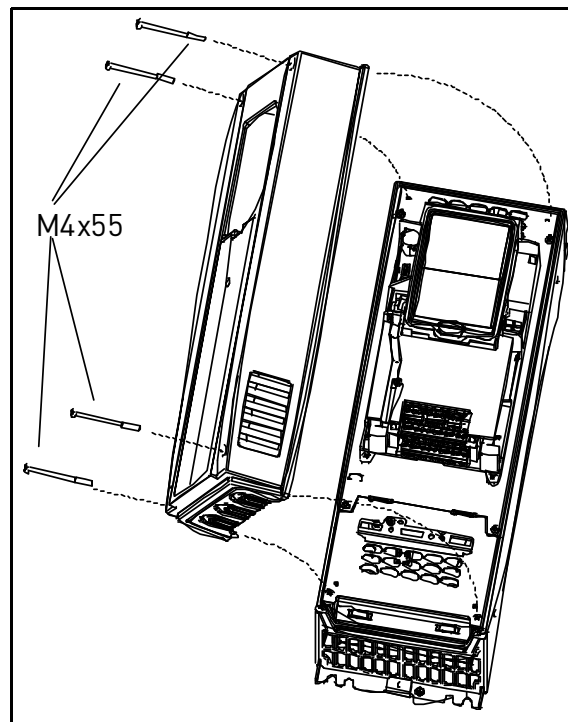

Figure 20.

3 Remove the screws of the cable protection plate. Do not open the cover of the power unit!

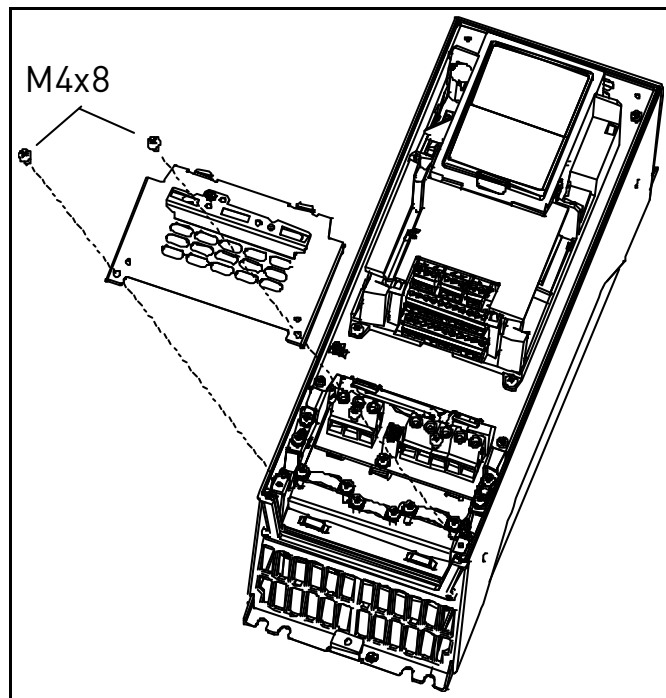

Figure 21.

4 Insert the cable grommets (included in the delivery) in the openings of the cable entry plate (included) as shown in the picture (upper pictures EU version, lower pictures US version).

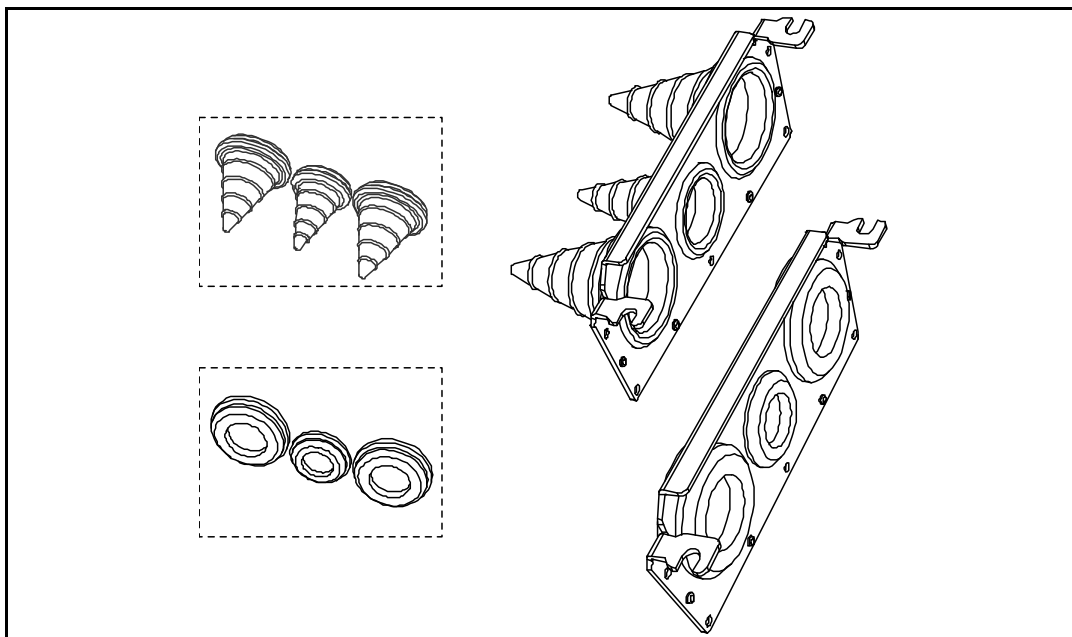

Figure 22.

5

- Insert the cables - supply cable, motor cable and optional brake cable - in the openings of the cable entry plate.
- Then cut the rubber grommets open to slide the cables through. Should the grommets fold in while inserting the cable, just draw the cable back a bit to straighten the grommets up.
- Do not cut the grommet openings wider than what is necessary for the cables you are using.

IMPORTANT NOTE FOR IP54 INSTALLATION:

To meet the requirements of the enclosure class IP54, the connection between the grommet and the cable must be tight. Therefore, lead the first bit of the cable out of the grommet **straight** before letting it bend. If this is not possible, the tightness of the connection must be ensured with insulation tape or a cable tie.

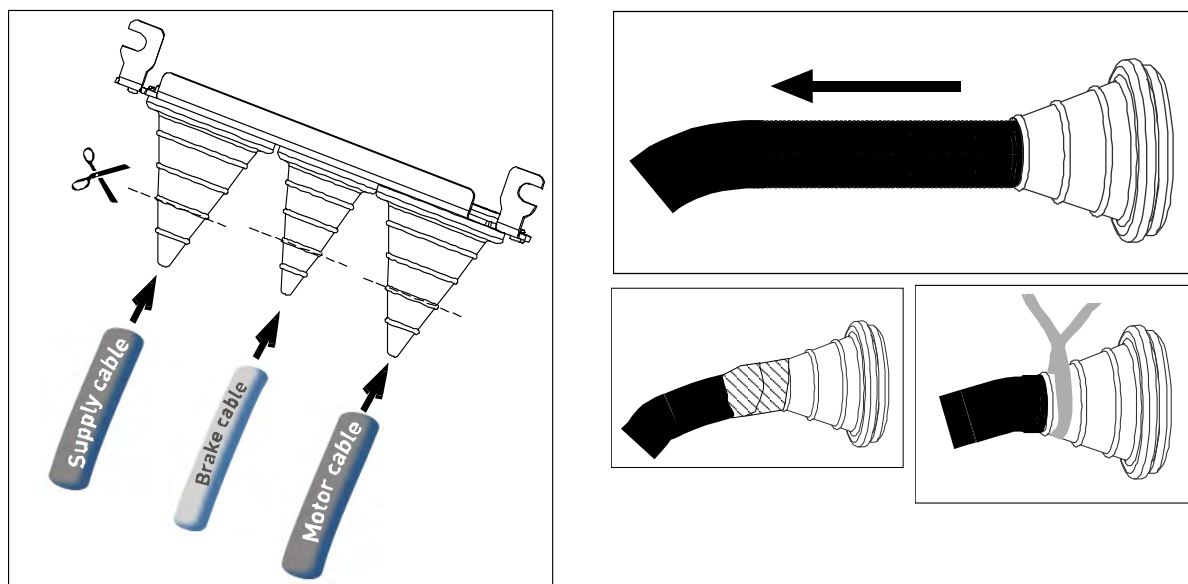

Figure 23.

6 Detach the cable clamps and the grounding clamps (Figure 24) and place the cable entry plate with the cables in the groove on the AC drive frame (Figure 25).

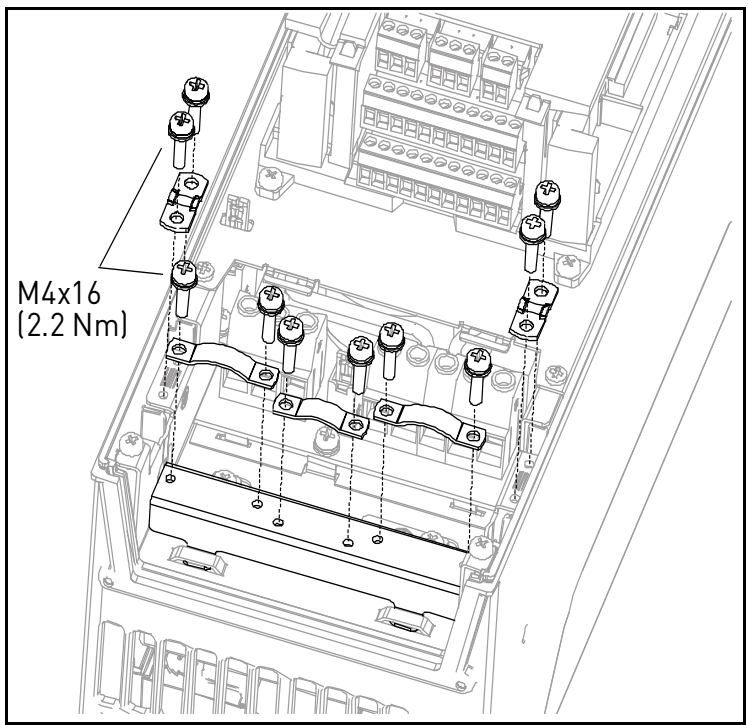

Figure 24.

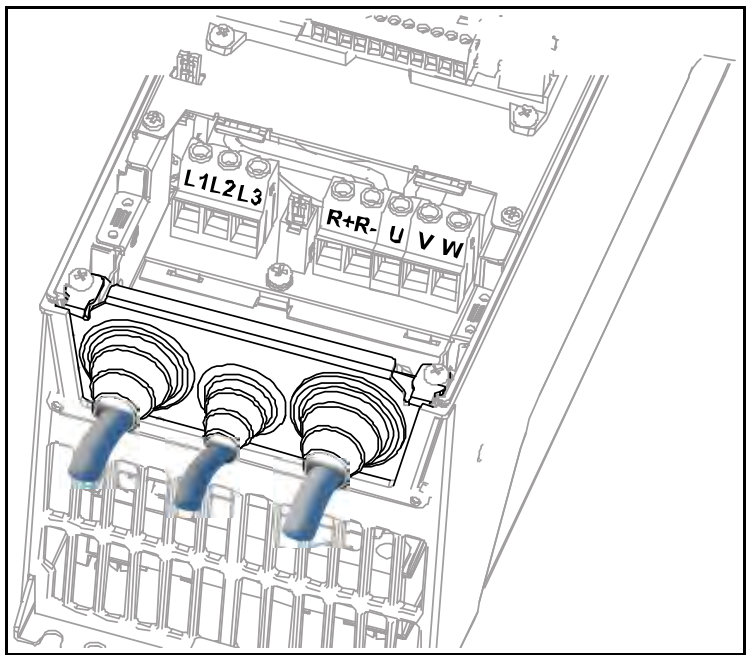

Figure 25.

- 7**
- Connect the stripped cables (see Figure 19 and Table 19) as shown in Figure 26.
- Expose the shield of all three cables in order to make a 360-degree connection with the cable clamp (1).
 - Connect the (phase) conductors of the supply, brake and motor cables into their respective terminals (2).
 - Form the rest of the cable shield of all three cables into “pigtails” and make a grounding connection with a clamp as shown in Figure 26 (3). Make the pigtails **just long enough** to reach and be fixed to the terminal - not longer.

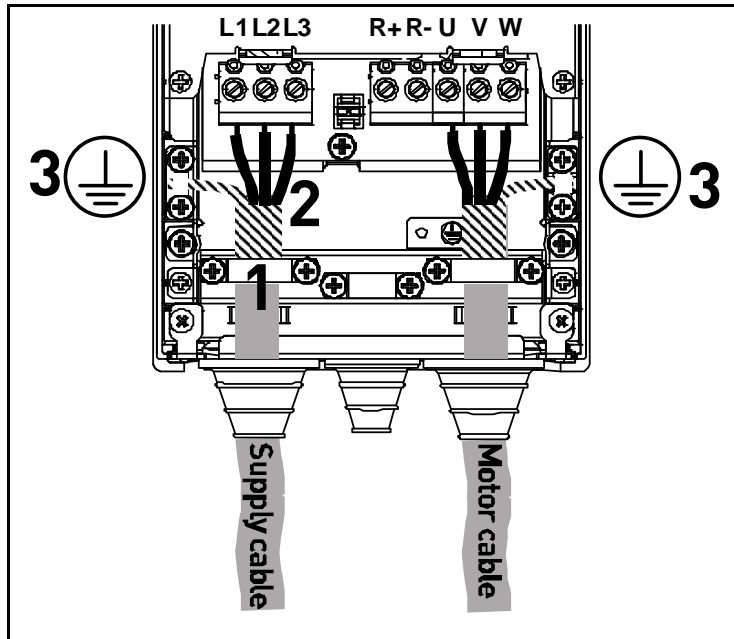



Figure 26.

Tightening torques of cable terminals:

Frame	Type	Tightening torque [Nm]/[lb-in.] Power and motor terminals		Tightening torque [Nm]/[lb-in.] EMC grounding clamps		Tightening torque, [Nm]/[lb-in.] Grounding terminals	
		[Nm]	lb-in.	[Nm]	lb-in.	[Nm]	lb-in.
MR4	0003 2—0012 2	0.5—0.6	4.5—5.3	1.5	13.3	2.0	17.7
	0003 4—0012 4						
MR5	0018 2—0031 2	1.2—1.5	10.6—13.3	1.5	13.3	2.0	17.7
	0016 4—0031 4						
MR6	0048 2—0062 2	10	88.5	1.5	13.3	2.0	17.7
	0038 4—0061 4						
MR7	0075 2—0105 2	8/15*	70.8/132.8*	1.5	13.3	8/15*	70.8/132.8*
	0072 4—0105 4						

*. Cable clamping (e.g. Ouneva Pressure Terminal Connector)

Table 20. Tightening torques of terminals

8 Check the connection of the earth cable to the motor and the AC drive terminals marked with  .
NOTE: Two protective conductors are required according to standard EN61800-5-1. See Figure 27 and chapter Earthing and earth fault protection. Use an M5 size screw and tighten it to 2.0 Nm (17.7 lb-in.).

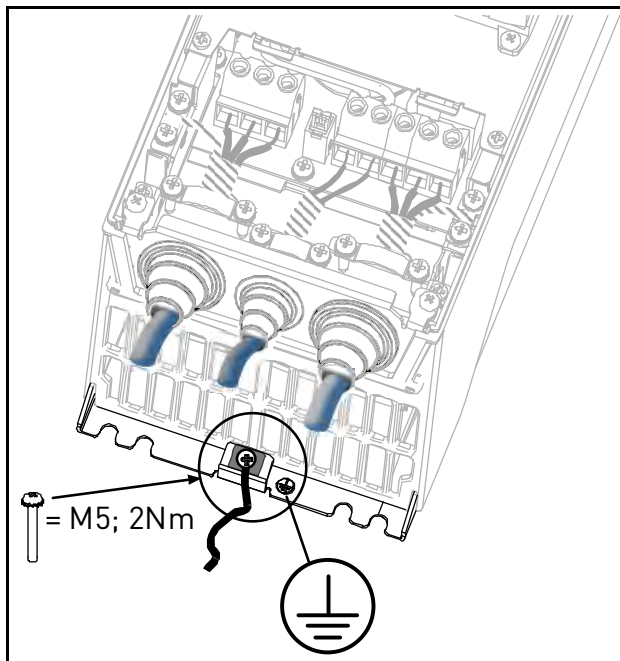

Figure 27. Additional protective earthing connector

9 Re-mount the cable protection plate (Figure 28) and the cover of the AC drive.

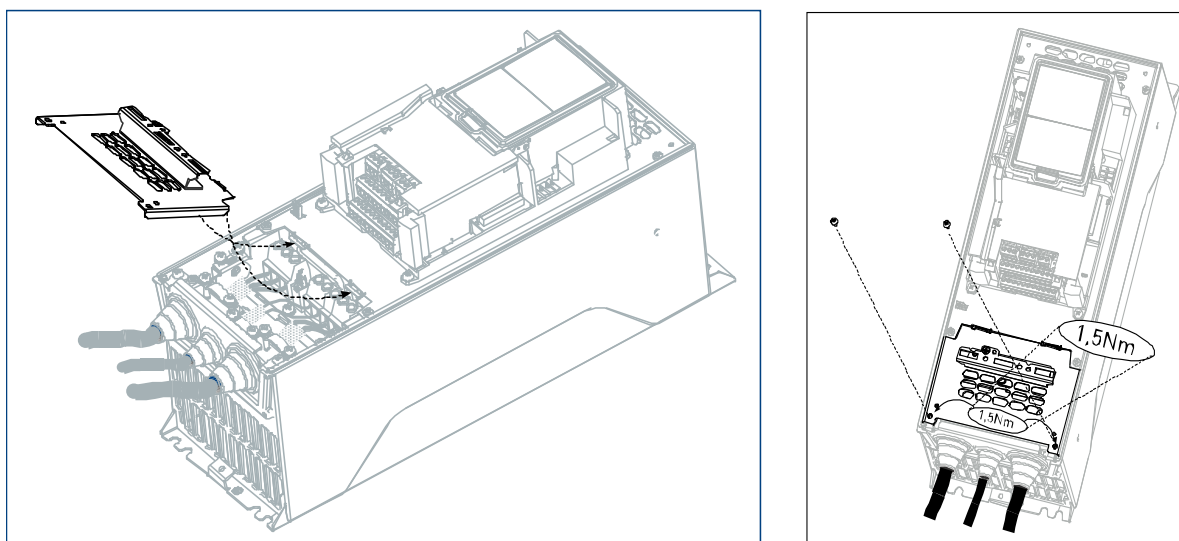

Figure 28. Re-mounting of cover components

4.3.2 FRAMES MR8 AND MR9

1 Strip the motor and mains cables as advised below.

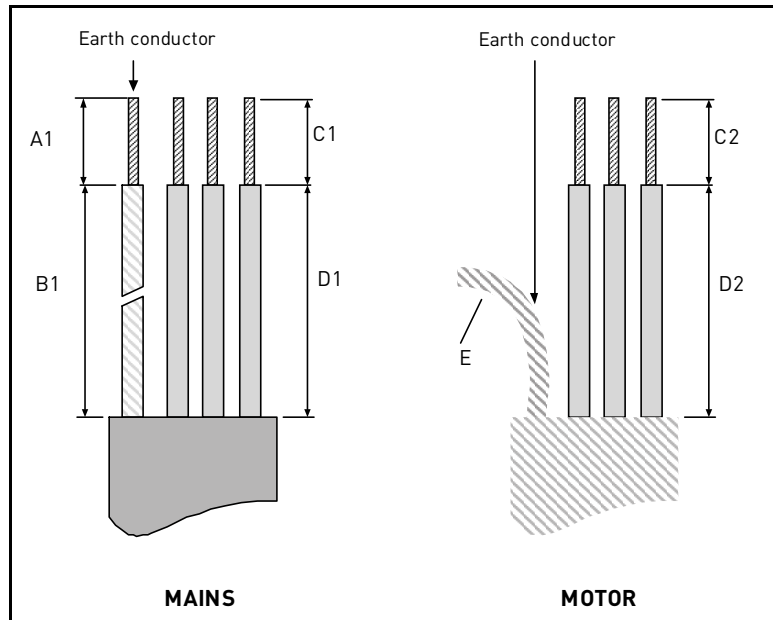

Figure 29. Stripping of cables

Frame	A1	B1	C1	D1	C2	D2	E
MR8	40	180	25	300	25	300	Leave as short as possible
MR9	40	180	25	300	25	300	

Table 21. Cables stripping lengths [mm]

2 **MR9 only:** Remove the main cover of the AC drive.

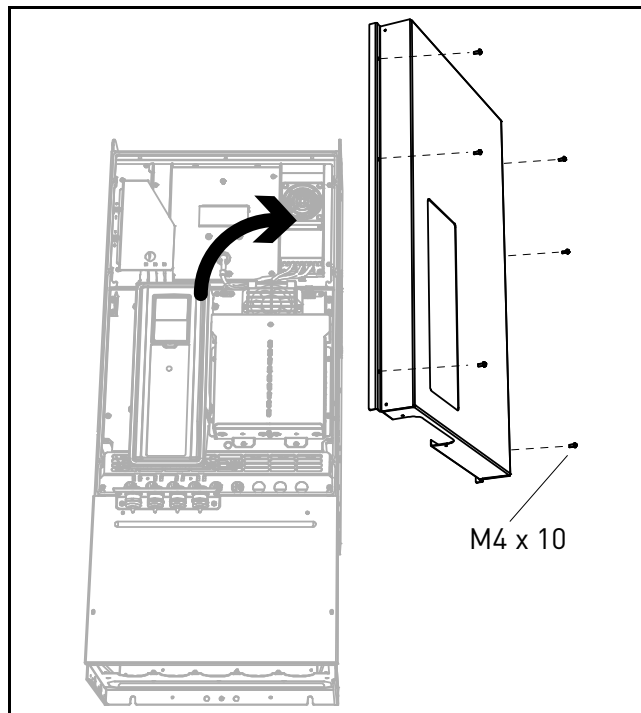

Figure 30.

3 Remove the cable cover (1) and the cable fitting plate (2).

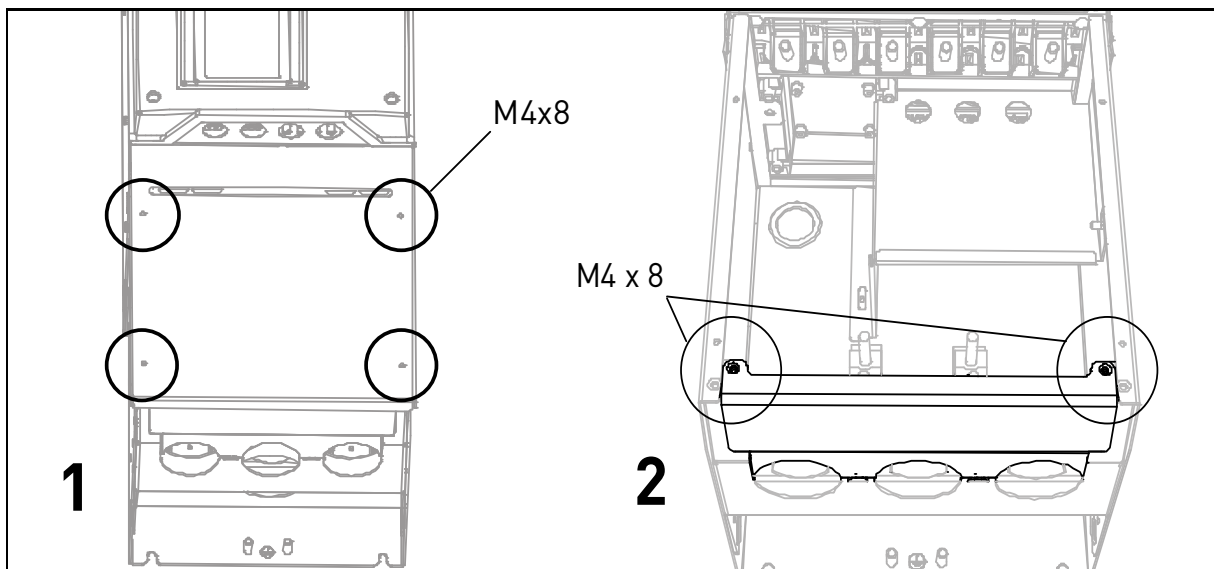

Figure 31. Removing cable cover and cable fitting plate (MR8).

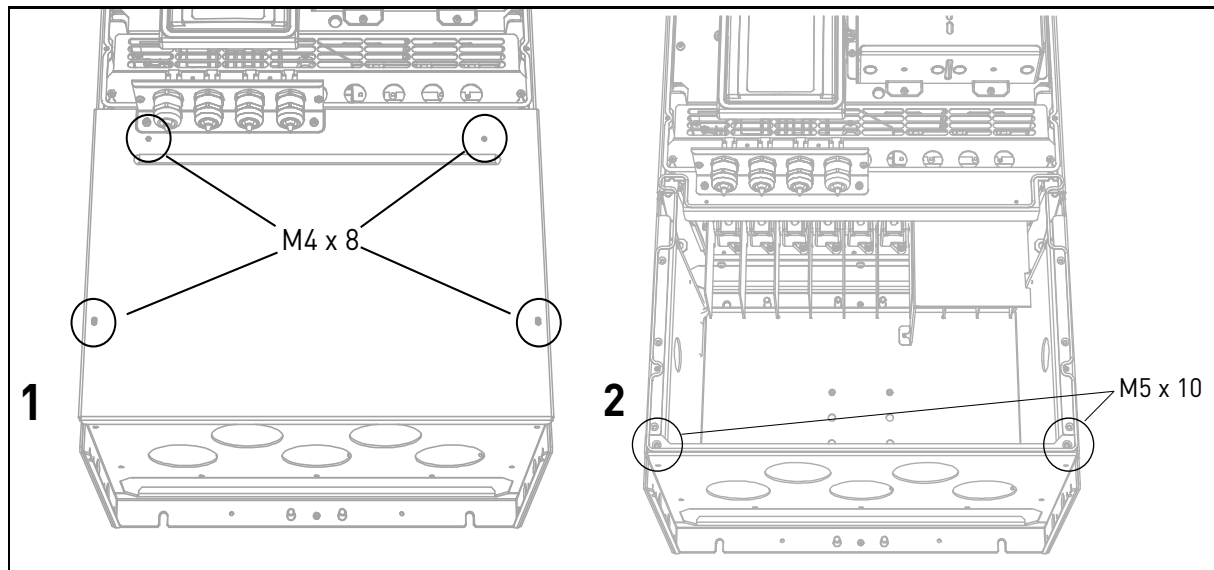

Figure 32. Removing cable cover and cable fitting plate (MR9).

4 MR9 only: Loosen the screws and remove the sealing plate.

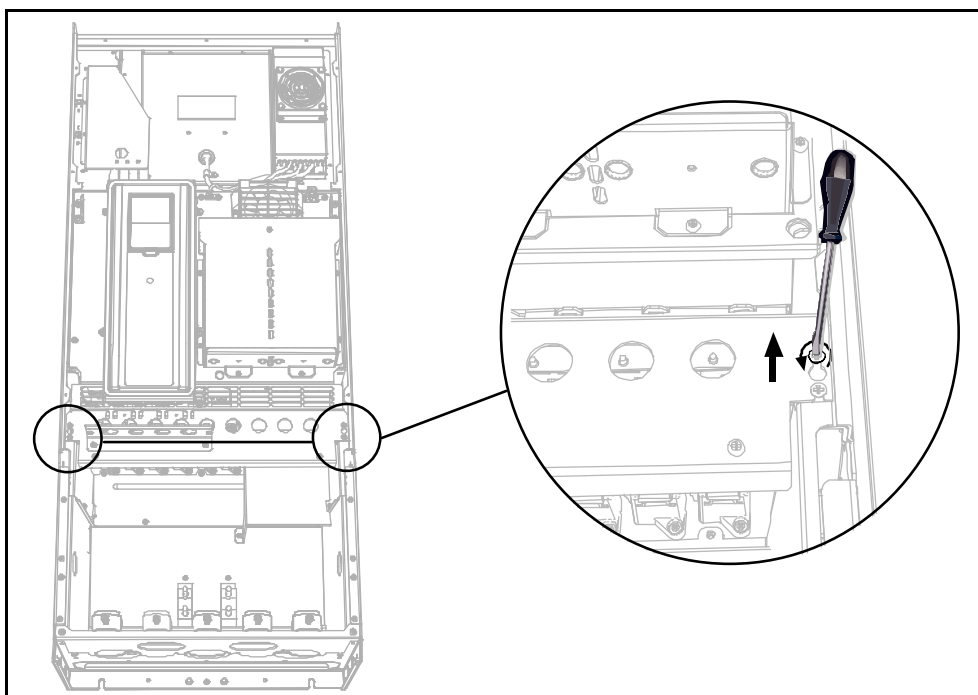

Figure 33.

5 Remove the EMC shield plate.

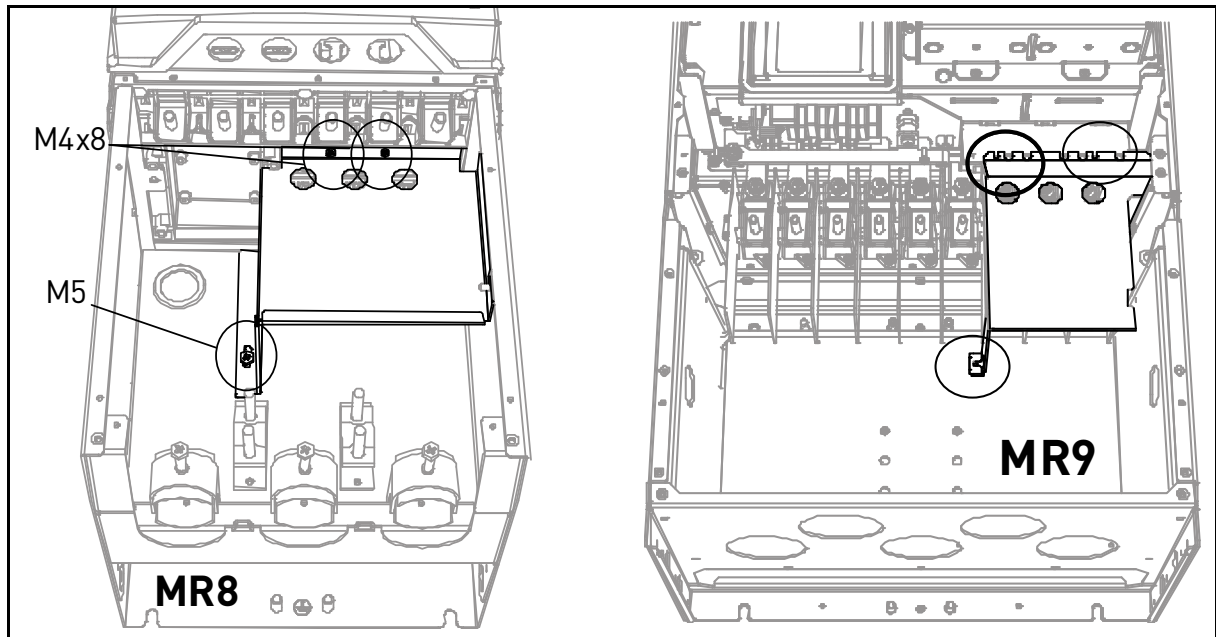

Figure 34.

6 Locate the terminals. **OBSERVE** the exceptional placement of motor cable terminals in MR8!

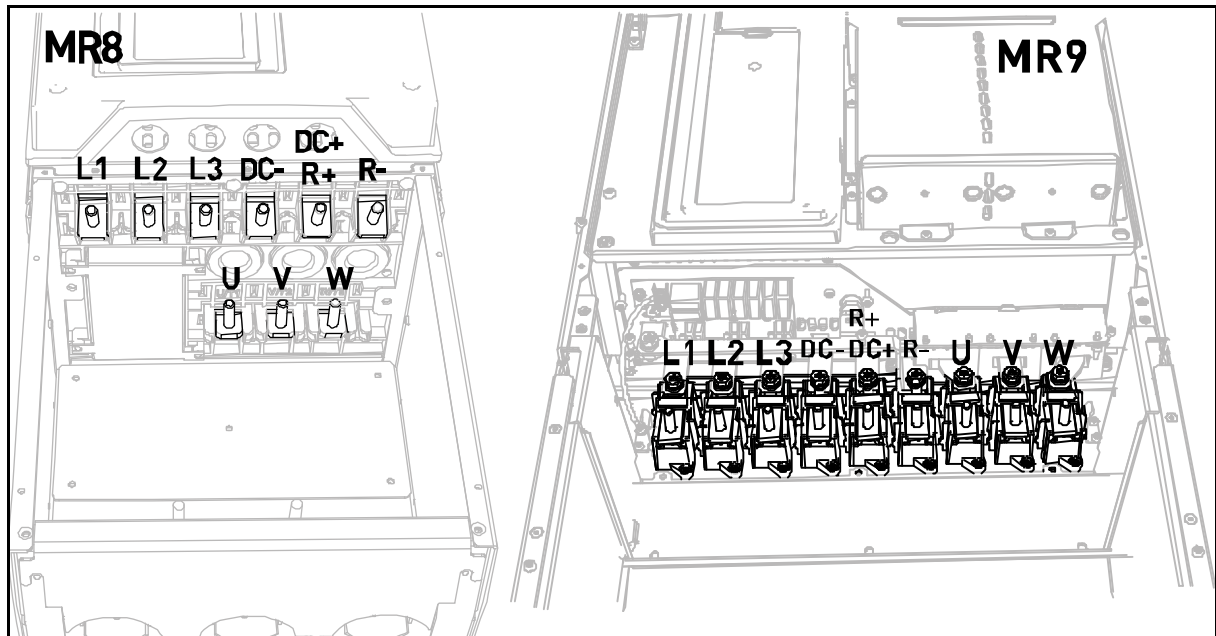

Figure 35.

7

Cut the rubber grommets open to slide the cables through. Should the grommets fold in while inserting the cable, just draw the cable back a bit to straighten the grommets up. Do not cut the grommet openings wider than what is necessary for the cables you are using.

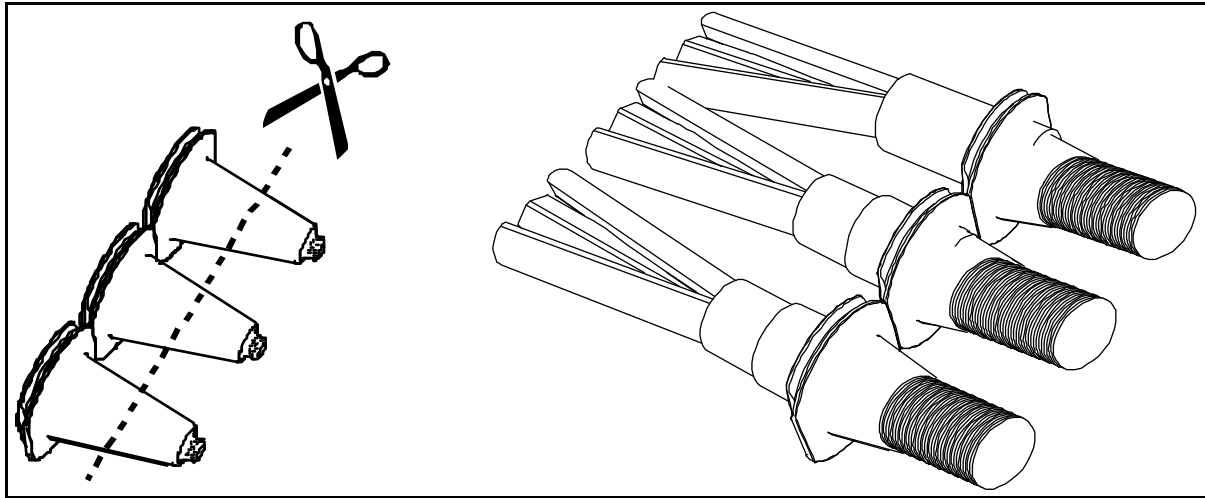

Figure 36.

8

Place the grommet with the cable so that the frame end plate fits in the groove on the grommet, see Figure 37. To meet the requirements of the enclosure class IP54, the connection between the grommet and the cable must be tight. Therefore, lead the first bit of the cable out of the grommet **straight** before letting it bend. If this is not possible, the tightness of the connection must be ensured with insulation tape or a cable tie. As an example, see Figure 23.

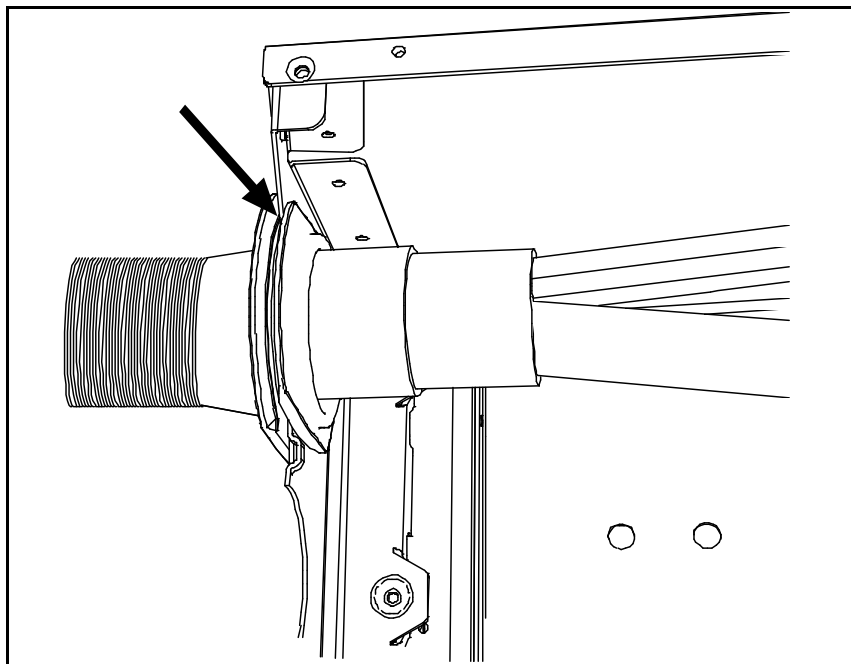

Figure 37.

9 If you use thick cables insert the cable insulators in between the terminals in order to avoid contact between the cables.

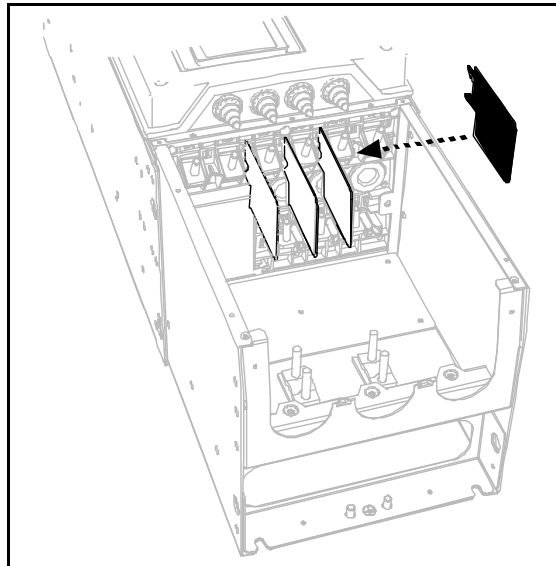

Figure 38.

10 Connect the cables stripped as shown in Figure 29.

- Connect the (phase) conductors of the supply, brake and motor cables into their respective terminals (a).
- Form the rest of the cable shield of all cables into “pigtails” and make a grounding connection as shown in Figure 39 (b) using the clamp from the *Accessories bag*.
- **NOTE:** If you use several cables on one connector observe the position of cable lugs on top of each other. See Figure 40 below.

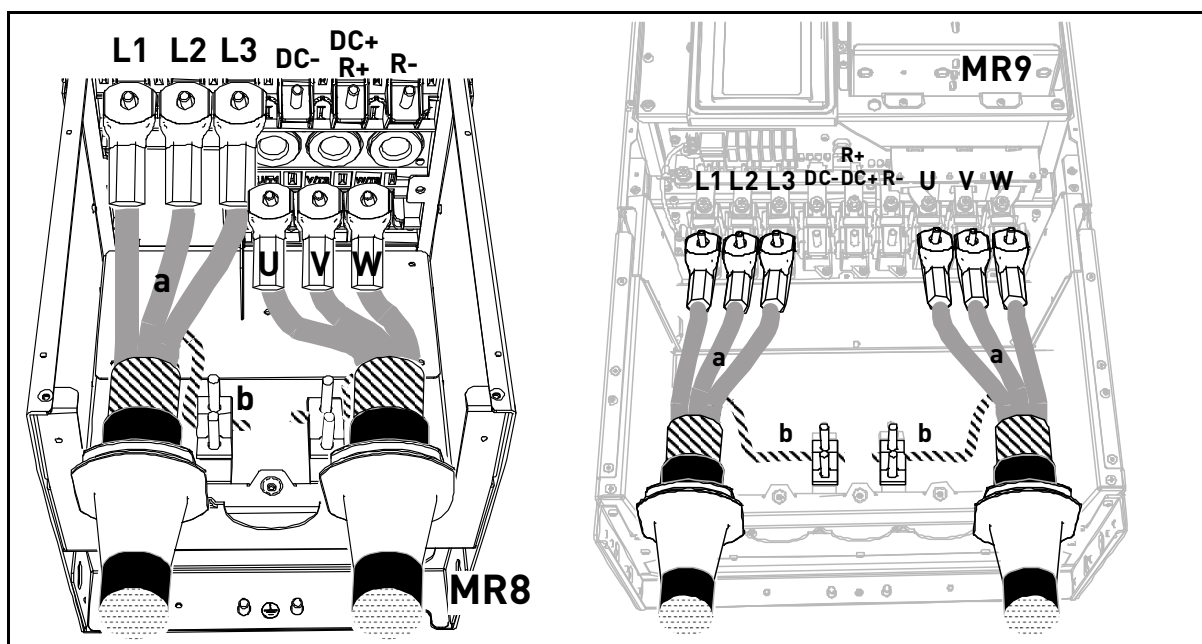

Figure 39.

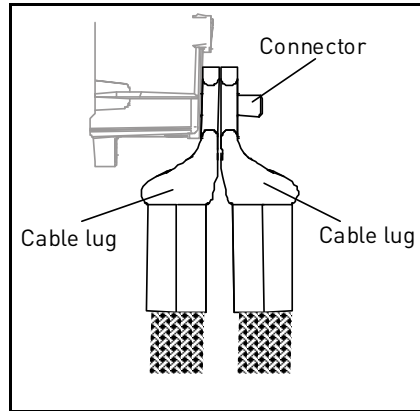

Figure 40. Placing two cable lugs on top of each other

Tightening torques of cable terminals:

Frame	Type	Tightening torque [Nm]/[lb-in.] Power and motor terminals		Tightening torque [Nm]/[lb-in.] EMC grounding clamps		Tightening torque, [Nm]/[lb-in.] Grounding terminals	
		[Nm]	lb-in.	[Nm]	lb-in.	[Nm]	lb-in.
MR8	0140 2—0205 2	20/40*	177/354*	1.5	13.3	20	177
	0140 4—0205 4						
MR9	0261 2—0310 2	20/40*	177/354*	1.5	13.3	20	177
	0261 4—0310 4						

*. Cable clamping (e.g. Ouneva Pressure Terminal Connector)

Table 22. Tightening torques of terminals

11 Expose the shield of all three cables in order to make a 360-degree connection with the cable clamp.

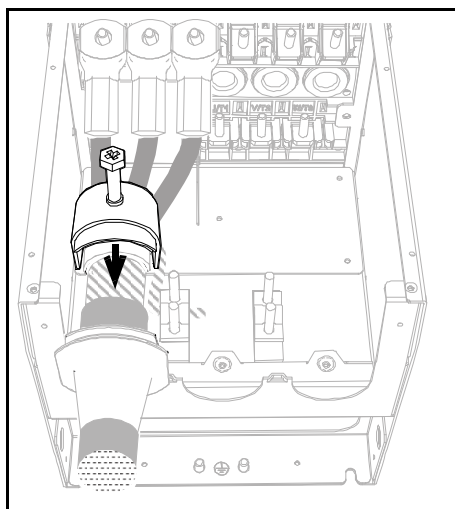

Figure 41.

12

Remount now first the EMC shield plate (see Figure 34) and then the sealing plate for MR9 (see Figure 33).

13

Re-attach then the cable fitting plate and then the cable cover.

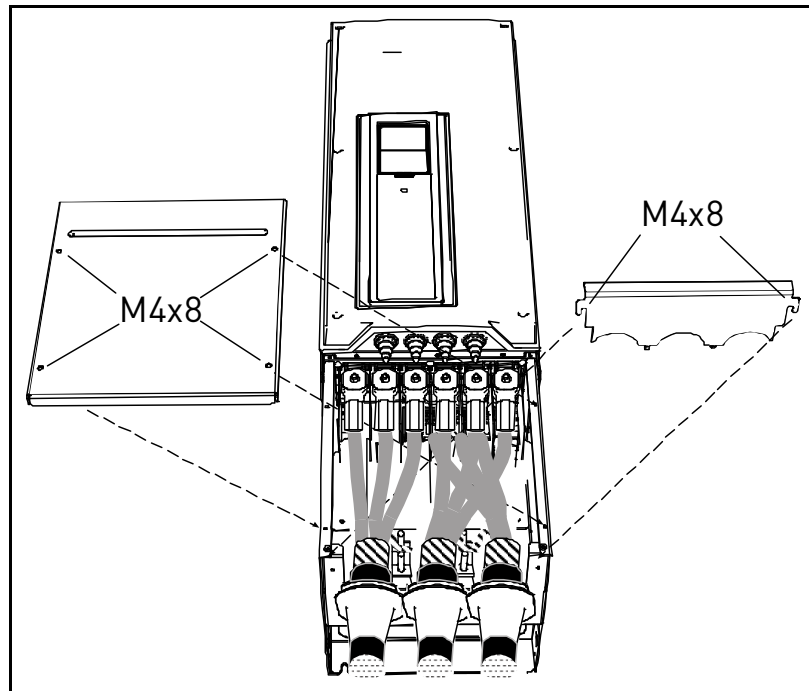

Figure 42.

14

MR9 only: Now re-mount the main cover (unless you want to make the control connections first).

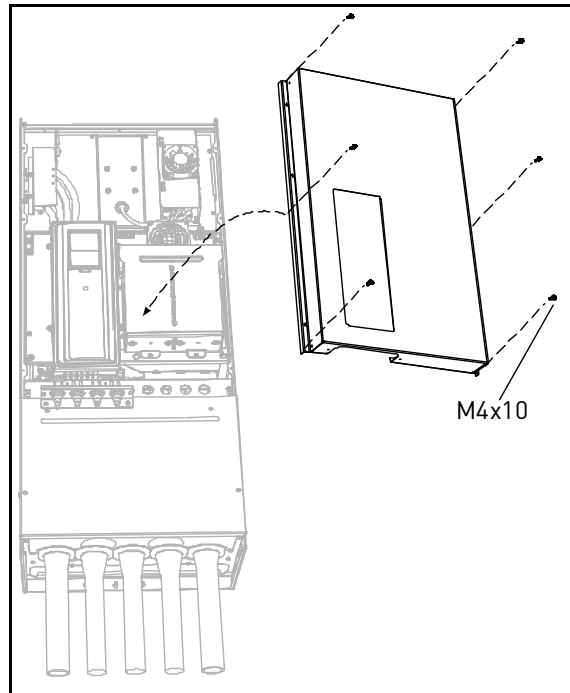



Figure 43.

15

Check the connection of the earth cable to the motor and the AC drive terminals marked with .

NOTE: Two protective conductors are required according to standard EN61800-5-1. See chapter Earthing and earth fault protection.

Connect the protective conductor using a cable shoe and an M8 screw (included in the *Accessories bag*) on **either** of the screw connectors as advised in Figure 44.

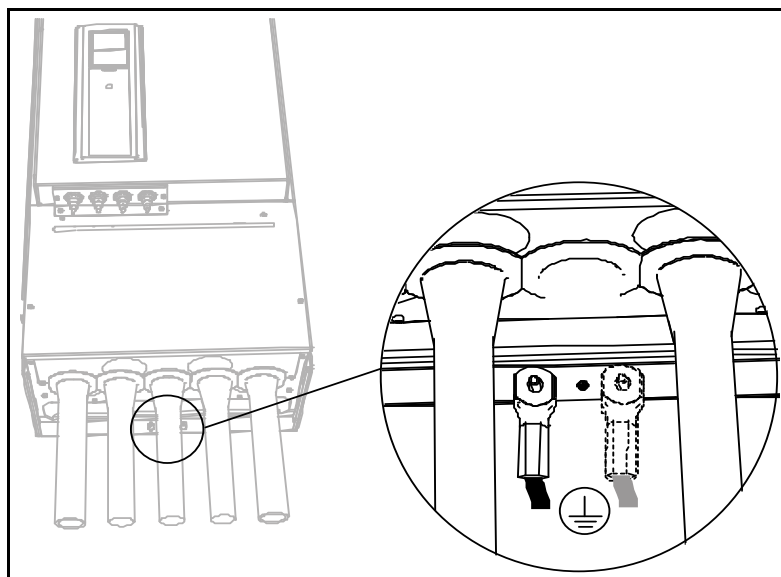

Figure 44.

4.4 INSTALLATION IN CORNER-GROUNDED NETWORK

Corner grounding is allowed for the drive types rating from 72 A to 310 A at 380...480 V supply and from 75 A to 310 A at 208...240 V supply.

In these circumstances the EMC protection class must be changed to level C4 following the instructions in chapter 6.3 of this manual.

Corner grounding is not allowed for the drive types with rating from 3.4 A to 61 A at 380...480 V supply and 3.7 A to 62 A with 208...240 V supply.

5. CONTROL UNIT

The control unit of the AC drive consists of the control board and additional boards (option boards) connected to the slot connectors of the control board.

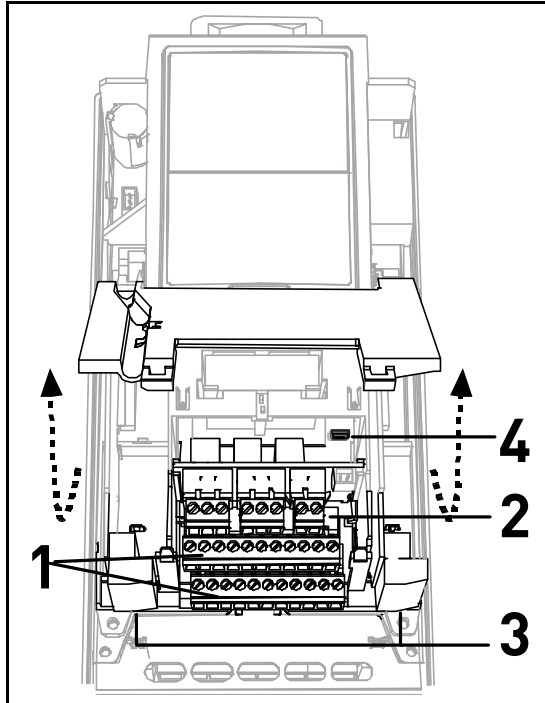

Locations of essential control unit components:

- 1 = Control terminals of the control board
- 2 = Terminals of relay board; **NOTE:** There are two different compilations of relay boards available. See section 5.1.
- 3 = Optional boards
- 4 = Jumper for digital inputs, see chapter 5.1.2.2

Figure 45. Location of control unit components

When delivered from the factory, the control unit of the AC drive contains the standard controlling interface - the control terminals of the control board and the relay board - unless otherwise specifically ordered. On the next pages you will find the arrangement of the control I/O and the relay terminals, the general wiring diagram and the control signal descriptions.

The control board can be powered externally (+24VDC, 100mA, ±10%) by connecting the external power source to terminal #30, see page 50. This voltage is sufficient for parameter setting and for keeping the control unit active. Note however that the measurements of the main circuit (e.g. DC-link voltage, unit temperature) are not available when the mains is not connected.

5.1 CONTROL UNIT CABLING

The basic control unit connections are presented in Figure 46 below. The control board is equipped with 22 fixed control I/O terminals and the relay board with 8 or 9. The relay board is available in two different configurations (see Table 25 and 26). All signal descriptions are given in Tables 24 to 26.

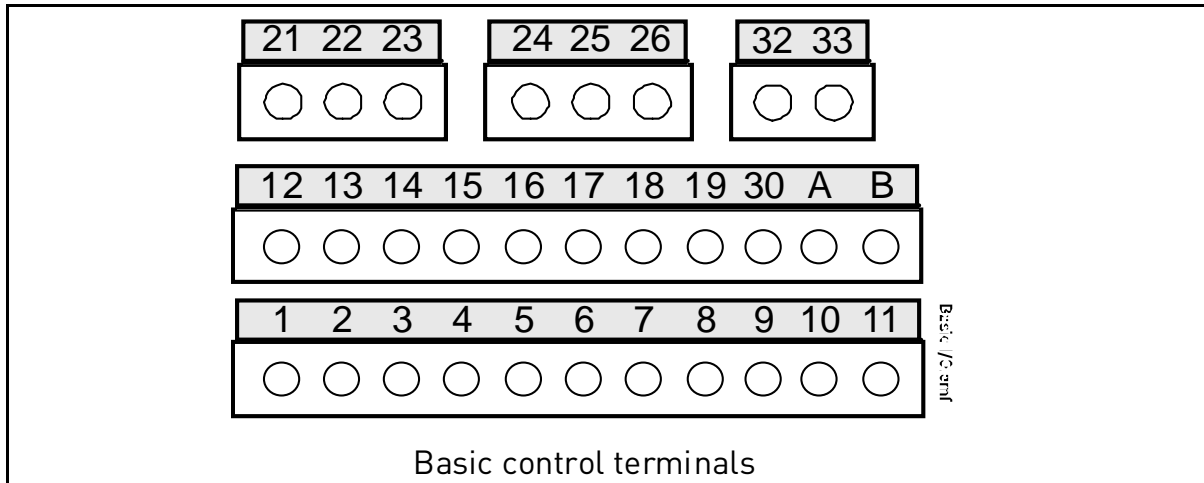

Figure 46.

5.1.1 CONTROL CABLE SIZING

The control cables shall be at least 0.5 mm² screened multicore cables, see Table 14. The maximum terminal wire size is 2.5 mm² for the relay and other terminals.

Find the tightening torques of the control and relay board terminals in Table 23 below.

Terminal screw	Tightening torque	
	Nm	lb-in.
All I/O and relay terminals (screw M3)	0.5	4.5

Table 23. Control cable tightening torques

5.1.2 CONTROL TERMINALS AND DIP SWITCHES

The terminals of the *Basic I/O board* and the *Relay boards* are described below. For more information on the connections, see chapter 7.2.1.

The terminals shown on shadowed background are assigned for signals with optional functions selectable with DIP switches. See more information in chapter 5.1.2.1 on page 52.

Basic I/O board		
Terminal	Signal	
1	+10 Vref	Reference output
2	AI1+	Analogue input, voltage or current
3	AI1-	Analogue input common (current)
4	AI2+	Analogue input, voltage or current
5	AI2-	Analogue input common (current)
6	24Vout	24V aux. voltage
7	GND	I/O ground
8	DI1	Digital input 1
9	DI2	Digital input 2
10	DI3	Digital input 3
11	CM	Common for DI1-DI6*
12	24Vout	24V aux. voltage
13	GND	I/O ground
14	DI4	Digital input 4
15	DI5	Digital input 5
16	DI6	Digital input 6
17	CM	Common for DI1-DI6*
18	AO1+	Analogue signal (+output)
19	AO-/GND	Analogue output common
30	+24 Vin	24V auxiliary input voltage
A	RS485	Serial bus, negative
B	RS485	Serial bus, positive

*. Digital inputs can be isolated from ground, see chapter 5.1.2.2.

Table 24. Control I/O terminal signals on basic I/O board and connection example

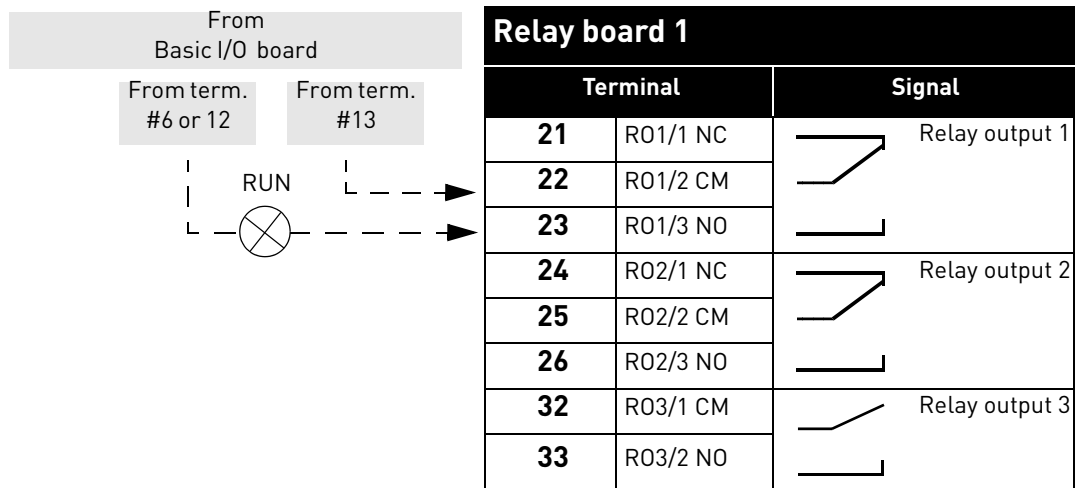

Table 25. Control I/O terminal signals on relay board 1 and connection example

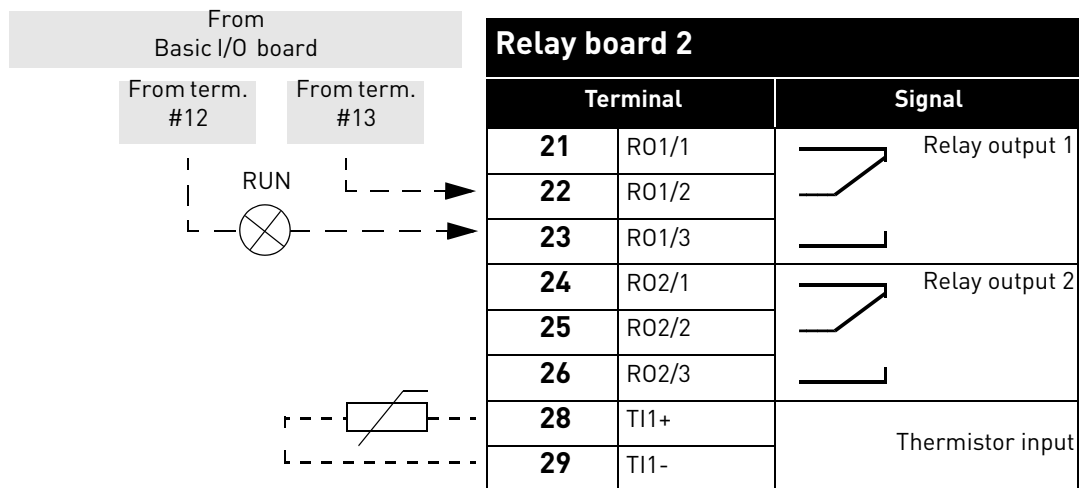

Table 26. Control I/O terminal signals on relay board 2 and connection example

5.1.2.1 SELECTION OF TERMINAL FUNCTIONS WITH DIP SWITCHES

The shadowed terminals in Table 24 allow for three functional selections each with the so-called *dip switches*. The switches have three positions, left, middle and right. The middle position is for *Test mode*. See figure to locate the switches and make appropriate selections for your requirements.

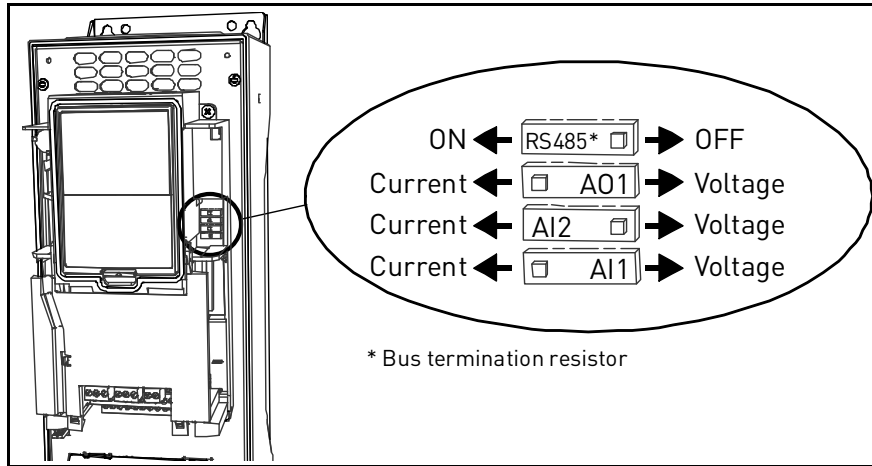

Figure 47. Dip switches

5.1.2.2 ISOLATING DIGITAL INPUTS FROM GROUND

The digital inputs (terminals 8-10 and 14-16) on the basic I/O board can be isolated from ground by removing a jumper on the control board. See Figure 48. Lift the plastic lid to expose the jumper and apply long-nose pliers or similar to remove it.

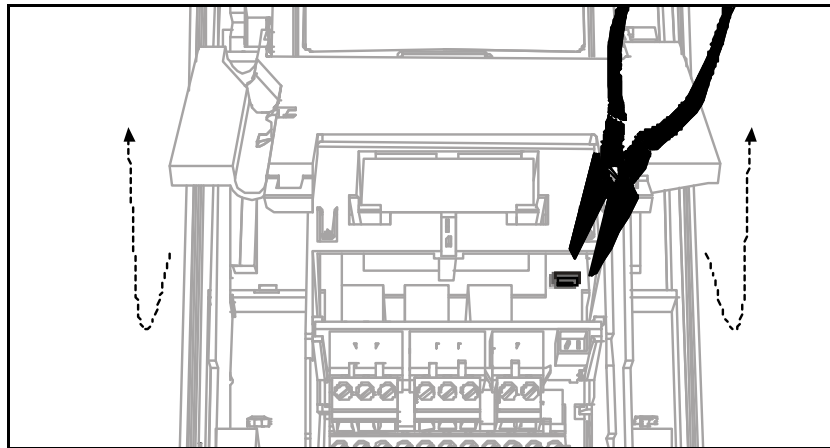

Figure 48. Remove this jumper to isolate the digital inputs from ground.

5.2 I/O CABLING AND FIELDBUS CONNECTION

The AC drive can be connected to fieldbus either through RS485 or Ethernet. The connection for RS485 is on the basic I/O board (terminals A and B) and the connection for Ethernet is under the drive cover, left to the control keypad. See Figure 49.

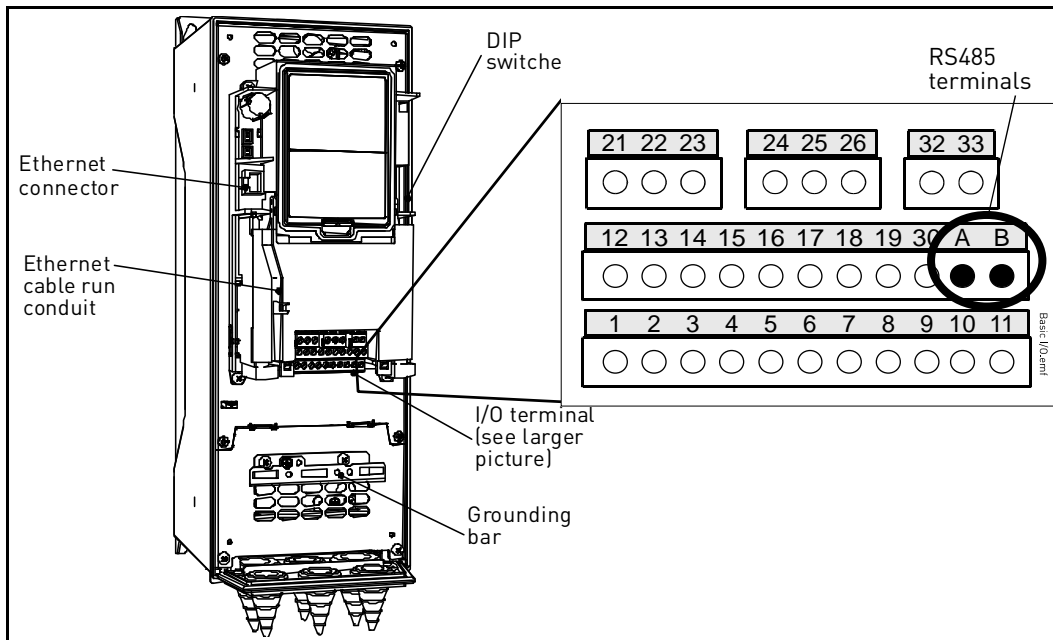

Figure 49.

5.2.1 PREPARE FOR USE THROUGH ETHERNET

5.2.1.1 ETHERNET CABLE DATA

Connector	Shielded RJ45 connector; NOTE: Max length of the connector 40mm.
Cable type	CAT5e STP
Cable length	Max .100m

Table 27. Ethernet cable data

- | | |
|----------|--|
| 1 | <p>Connect the Ethernet cable (see specification on page 53) to its terminal and run the cable through the conduit as shown in Figure 50.</p> <p>NOTE: Pay attention that the length of the connector does not exceed 40 mm. See Figure 50.</p> |
|----------|--|

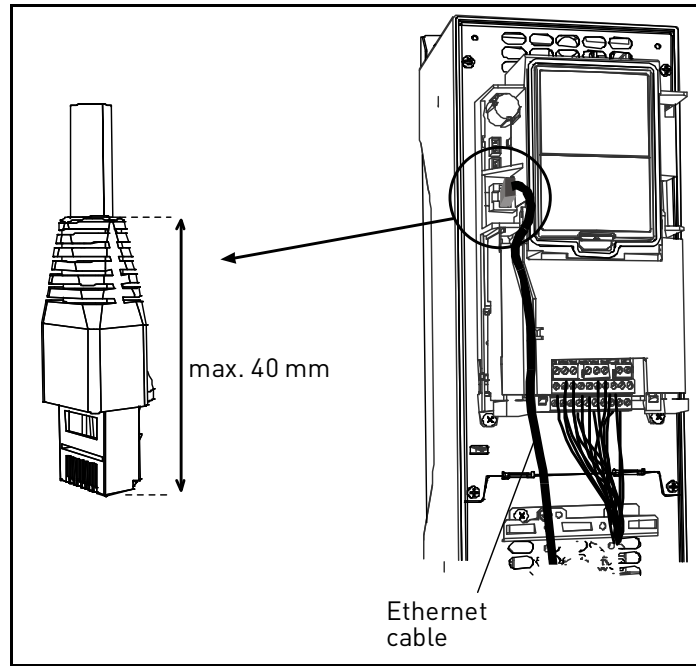

Figure 50.

2	<p>Protection class IP21: Cut free the opening on the AC drive cover for the Ethernet cable.</p> <p>Protection class IP54: Cut the rubber grommets open to slide the cables through. Should the grommets fold in while inserting the cable, just draw the cable back a bit to straighten the grommets up. Do not cut the grommet openings wider than what is necessary for the cables you are using.</p> <p>IMPORTANT: To meet the requirements of the enclosure class IP54, the connection between the grommet and the cable must be tight. Therefore, lead the first bit of the cable out of the grommet straight before letting it bend. If this is not possible, the tightness of the connection must be ensured with insulation tape or a cable tie.</p>
---	---

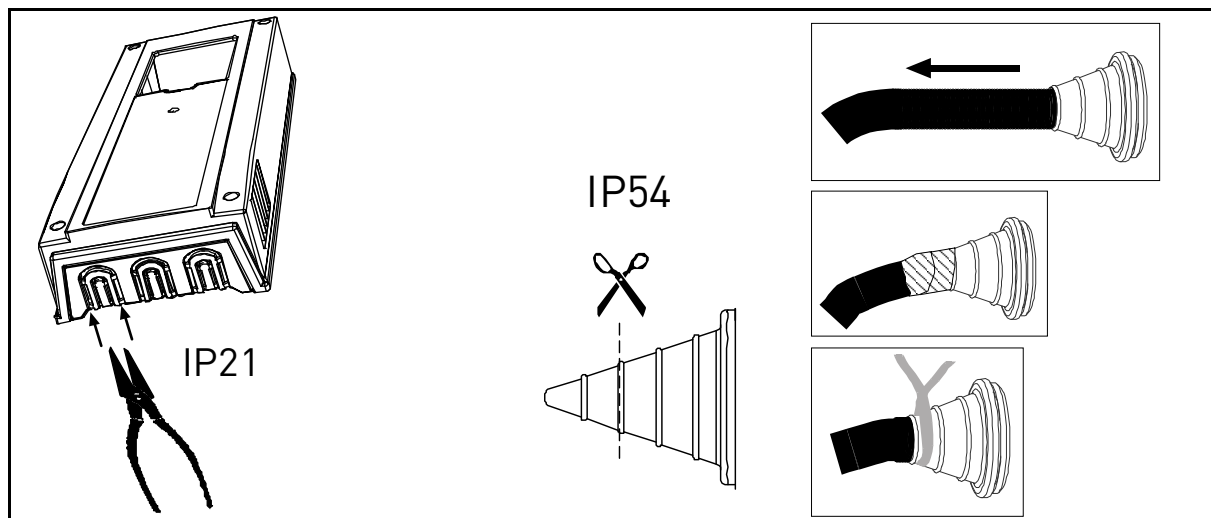

Figure 51.

3 Remount the AC drive cover. **NOTE:** When planning the cable runs, remember to keep the distance between the Ethernet cable and the motor cable at a **minimum of 30 cm.**

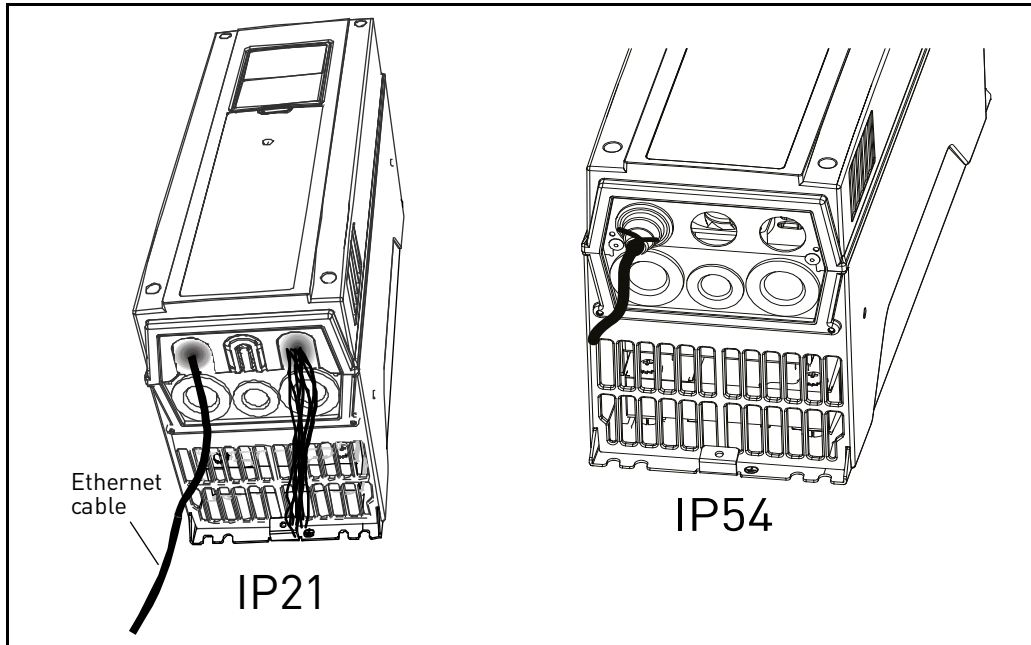

Figure 52.

For more detailed information, see the user’s manual of the fieldbus you are using.

5.2.2 PREPARE FOR USE THROUGH RS485

5.2.2.1 RS485 CABLE DATA

Connector	2.5 mm ²
Cable type	STP (Shielded Twisted Pair), type Belden 9841 or similar
Cable length	Depends on the used fieldbus. See respective bus manual.

Table 28. RS485 cable data

Strip about 15 mm of the RS485 cable (see specification on page 55) and cut off the grey cable shield. Remember to do this for both bus cables. Leave no more than 10 mm of the cable outside the terminal block and strip the cables at about 5 mm to fit in the terminals. See picture below.

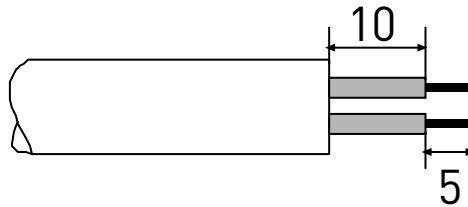

1

Also strip the cable now at such a distance from the terminal that you can fix it to the frame with the grounding clamp. Strip the cable at a maximum length of 15 mm. **Do not strip the aluminum cable shield!**

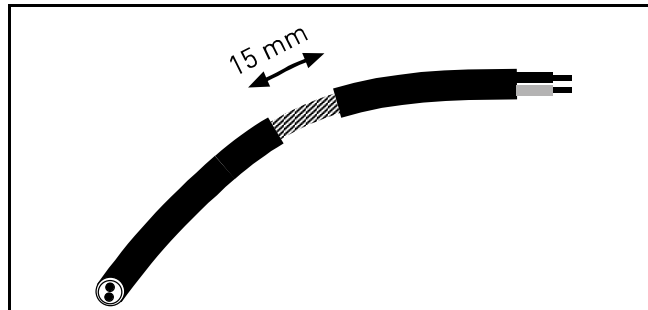

2

Then connect the cable to its appropriate terminals on Vacon 100 AC drive standard terminal block, terminals **A** and **B** (A = negative, B = positive). See Figure 53.

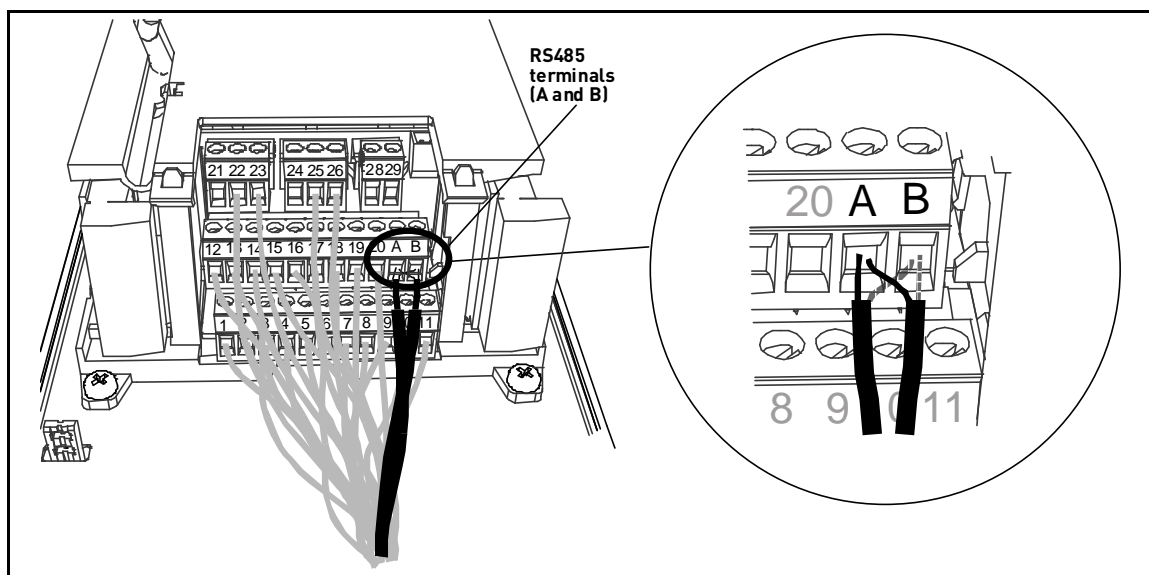
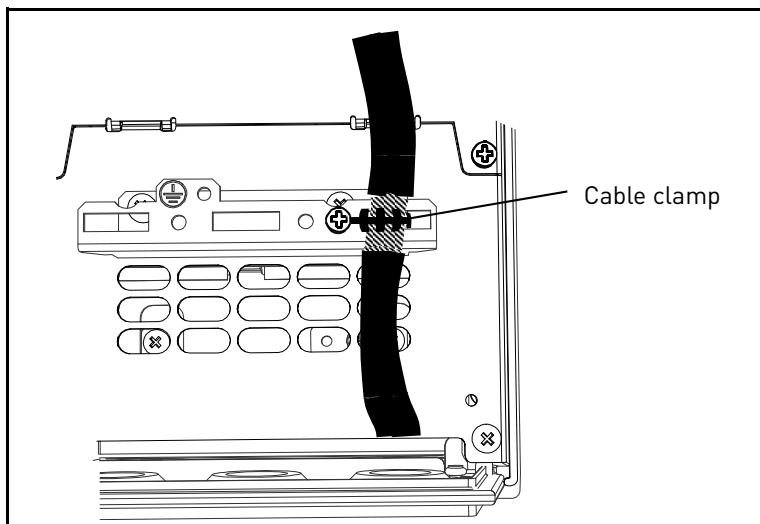

Figure 53.

3

Using the cable clamp included in the delivery of the drive, ground the shield of the RS485 cable to the frame of the AC drive.



4

If the AC drive is the last device on the bus, the bus termination must be set. Locate the DIP switches to the right of the control keypad of the drive and turn the switch for the RS485 bus termination resistor to position ON. Biasing is built in the termination resistor. See also step 7 on page 58.

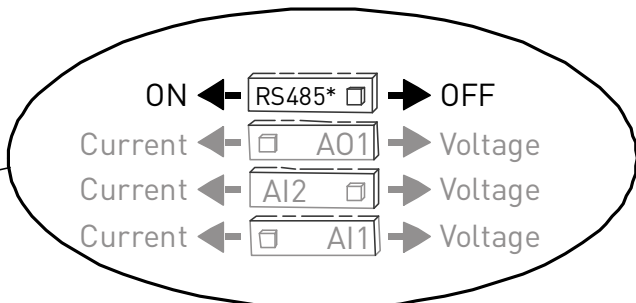
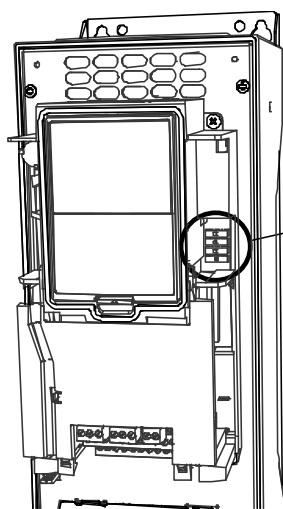

* Bus termination resistor

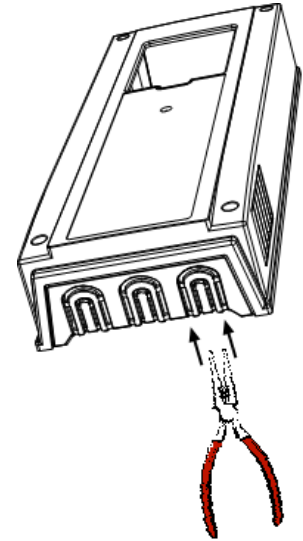
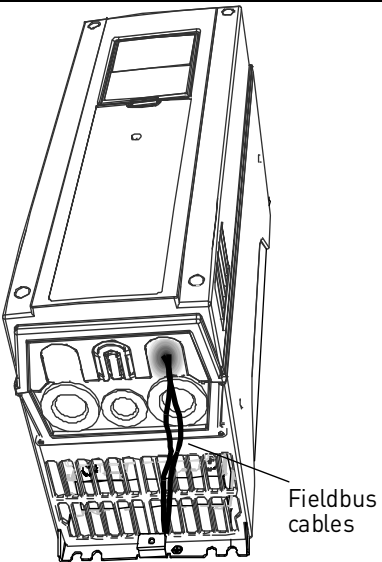
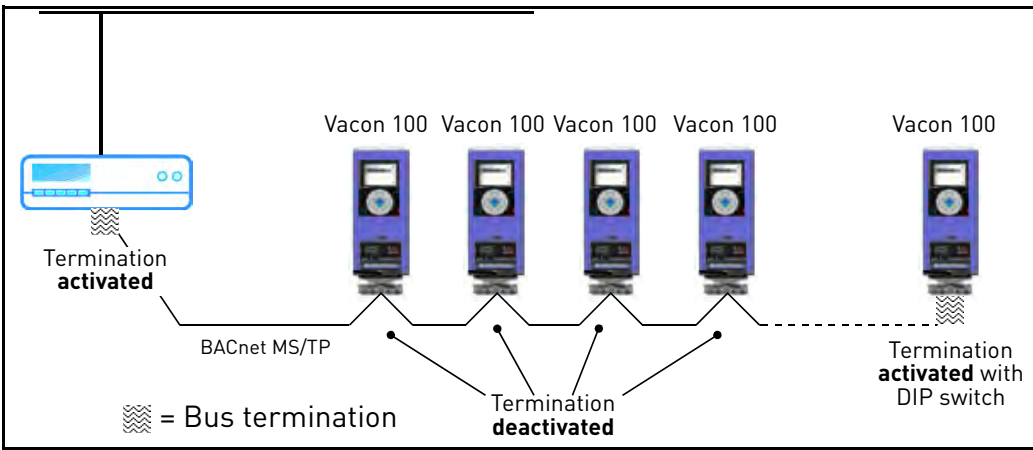
<p style="text-align: center; font-size: 24pt; font-weight: bold;">5</p>	<p>Unless already done for the other control cables, cut free the opening on the AC drive cover for the RS485 cable (protection class IP21).</p>	
<p style="text-align: center; font-size: 24pt; font-weight: bold;">6</p>	<p>Remount the AC drive cover and run the RS485 cables as shown in picture. NOTE: When planning the cable runs, remember to keep the distance between the fieldbus cable and the motor cable at a minimum of 30 cm.</p>	
<p style="text-align: center; font-size: 24pt; font-weight: bold;">7</p>	<p>The bus termination must be set for the first and the last device of the fieldbus line. See picture below. See also step 4 on page 57. We recommend that the first device on the bus and, thus, terminated was the Master device.</p> 	

5.3 BATTERY INSTALLATION FOR REAL TIME CLOCK (RTC)

Enabling the functions of the *Real Time Clock (RTC)* requires that an optional battery is installed in the Vacon 100 HVAC drive.

The place for the battery can be found in all frames left to the control keypad (see Figure 54).

Detailed information on the functions of the *Real Time Clock (RTC)* can be found in the Vacon 100 HVAC Application Manual.

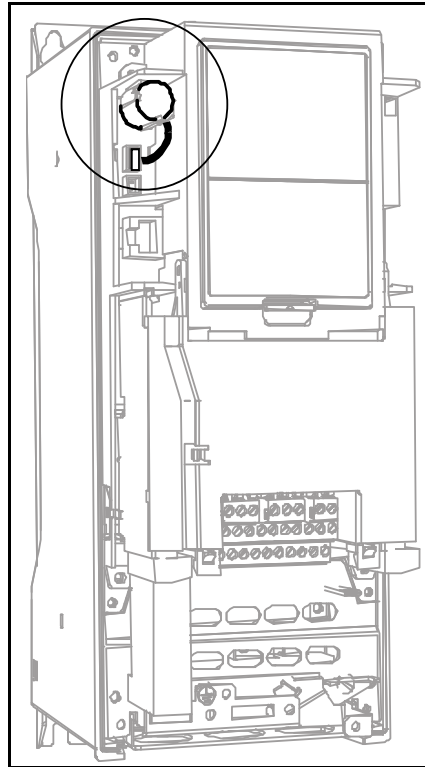

Figure 54. Optional battery

5.4 GALVANIC ISOLATION BARRIERS

The control connections are isolated from the mains potential and the GND terminals are permanently connected to ground. See Figure 55.

The digital inputs are galvanically isolated from the I/O ground. The relay outputs are additionally double-isolated from each other at 300VAC (EN-50178).

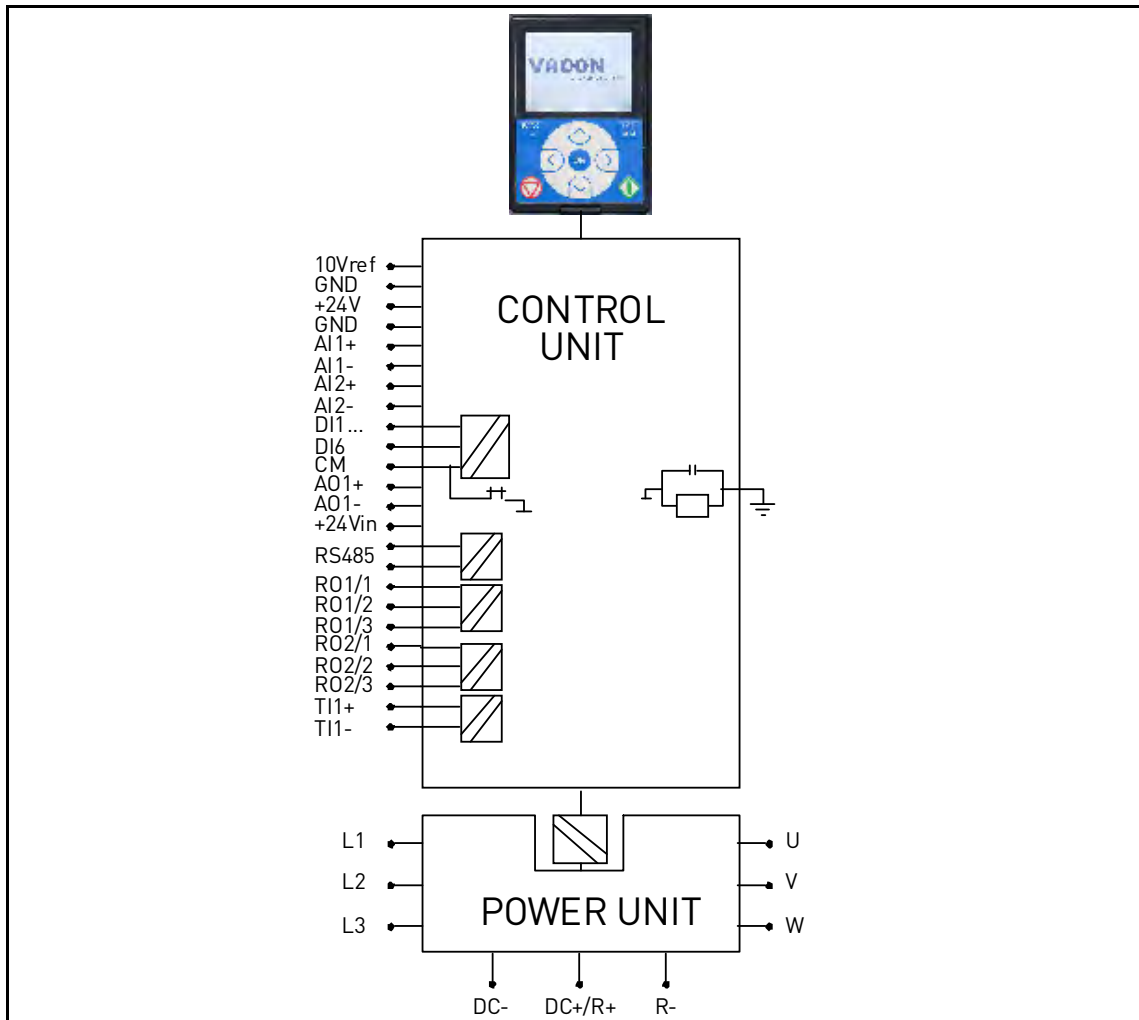

Figure 55. Galvanic isolation barriers

6. COMMISSIONING

Before commissioning, note the following directions and warnings:



Internal components and circuit boards of Vacon 100 (except for the galvanically isolated I/O terminals) are live when it is connected to mains potential. **Coming into contact with this voltage is extremely dangerous and may cause death or severe injury.**



The motor terminals **U, V, W** and the brake resistor terminals (**R+/R-** (MR4-MR6) or **DC+/R+** and **R-** (MR7 and bigger)) **are live** when Vacon 100 is connected to mains, **even if the motor is not running.**



The control I/O-terminals are isolated from the mains potential. However, the **relay outputs and other I/O-terminals may have a dangerous control voltage** present even when Vacon 100 is disconnected from mains.



Do not make any connections to or from the frequency converter when it is connected to the mains.



After disconnecting the frequency converter from the mains, **wait** until the fan stops and the indicators on the keypad go out (if no keypad is attached see the indicators on the cover). Wait 5 more minutes before doing any work on the connections of Vacon100. Do not open the cover before this time has expired. After expiration of this time, use a measuring equipment to absolutely ensure that no voltage is present. **Always ensure absence of voltage before electrical work!**



Before connecting the AC drive to mains make sure that the front and cable covers of Vacon 100 are closed.



Corner grounding is allowed for the drive types with ratings from 72 A to 310 A at 380...480 V supply and from 75 A to 310 A at 208...240 V supply. Remember to change the EMC level by removing the jumpers. See chapter 6.3.

6.1 COMMISSIONING OF THE DRIVE

Read carefully the safety instructions in Chapter 1 and above and follow them.

After the installation:

- Check that both the AC drive and the motor are **grounded**.
- Check that the mains and motor cables **comply with the requirements** given in chapter 4.1.1.
- Check that the control cables are **located as far as possible** from the power cables, see chapter 4.4.
- Check that the **shields** of the shielded cables are **connected to protective earth** marked with .
- Check the **tightening torques** of all terminals
- Check that the **wires do not touch** the electrical components of the drive.
- Check that the common inputs of digital input groups are connected to +24V or ground of the I/O terminal or the external supply.
- Check the **quality and quantity** of cooling air (chapter 3.2 and Table 13).
- Check the inside of the AC drive for **condensation**.
- Check that all Start/Stop switches connected to the I/O terminals are in Stop-position.**
- Before connecting the AC drive to mains: Check **mounting and condition** of all fuses and other protective devices.
- Run the Startup Wizard (see the Application Manual).

6.2 RUNNING THE MOTOR

MOTOR RUN CHECK LIST



Before starting the motor, check that the motor is **mounted properly** and ensure that the machine connected to the motor allows the motor to be started.



Set the maximum motor speed (frequency) according to the motor and the machine connected to it.



Before reversing the motor make sure that this can be done safely.



Make sure that no power correction capacitors are connected to the motor cable.



Make sure that the motor terminals are not connected to mains potential.

6.2.1 CABLE AND MOTOR INSULATION CHECKS

1. Motor cable insulation checks
Disconnect the motor cable from terminals U, V and W of the AC drive and from the motor. Measure the insulation resistance of the motor cable between each phase conductor as well as between each phase conductor and the protective ground conductor. The insulation resistance must be $>1\text{M}\Omega$ at ambient temperature of 20°C .
2. Mains cable insulation checks
Disconnect the mains cable from terminals L1, L2 and L3 of the AC drive and from the mains. Measure the insulation resistance of the mains cable between each phase conductor as well as between each phase conductor and the protective ground conductor. The insulation resistance must be $>1\text{M}\Omega$ at ambient temperature of 20°C .
3. Motor insulation checks
Disconnect the motor cable from the motor and open the bridging connections in the motor connection box. Measure the insulation resistance of each motor winding. The measurement voltage must equal at least the motor nominal voltage but not exceed 1000 V. The insulation resistance must be $>1\text{M}\Omega$ at ambient temperature of 20°C . Always follow the instructions of the motor manufacturer.

6.3 INSTALLATION IN IT SYSTEM

If your supply network is an IT (impedance-grounded) system but your AC drive is EMC-protected according to class C2 you need to modify the EMC protection of the AC drive to EMC-level C4. This is done by removing the built-in EMC jumpers with a simple procedure described below:

	<p>Warning! Do not perform any modifications on the AC drive when it is connected to mains.</p>
---	---

6.3.1 FRAMES MR4 TO MR6

1	<p>Remove the main cover of the AC drive (see page 32) and locate the jumpers connecting the built-in RFI-filters to ground. See Figure 56.</p>
---	---

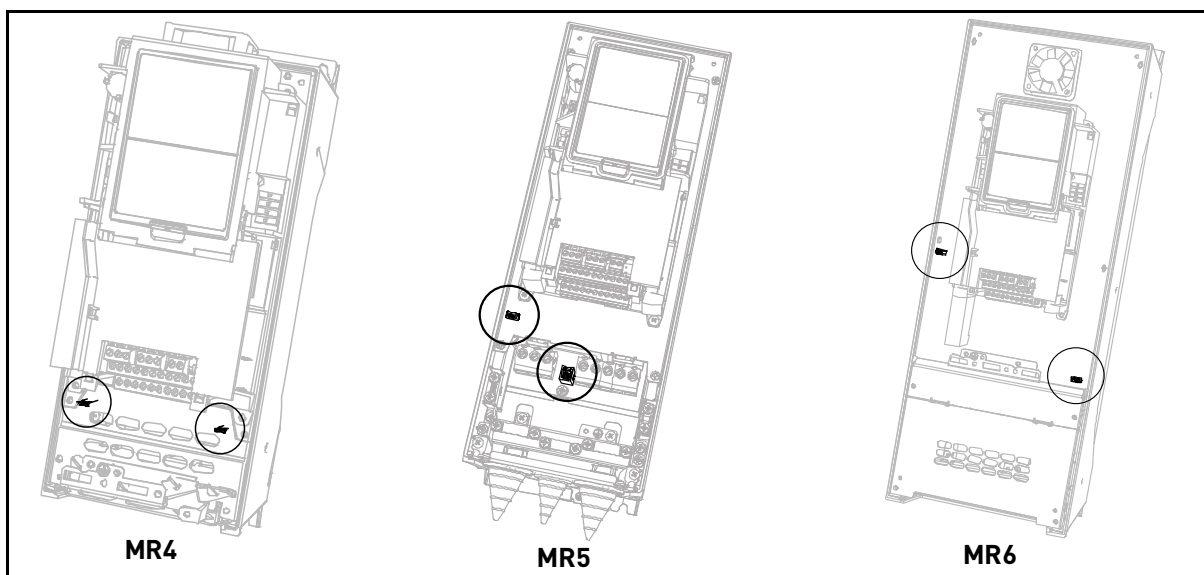

Figure 56. Locations of the EMC-jumpers in frames MR4 to MR6

2	<p>Disconnect the RFI-filters from ground by removing the EMC-jumpers using long-nose pliers or similar. See Figure 57.</p>
---	--

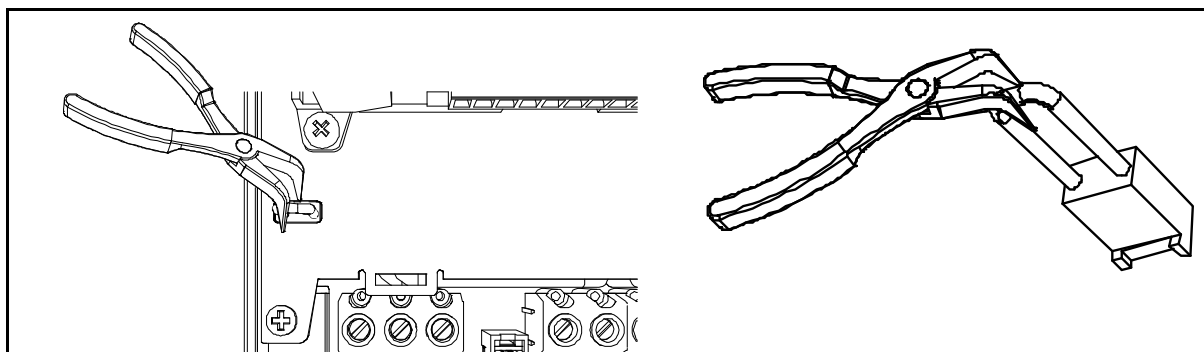

Figure 57. Removing the jumper, MR5 as example

6.3.2 FRAMES MR7 AND MR8

Follow the procedure described below to modify the EMC protection of the AC drive of frames MR7 and MR8 to EMC-level C4.

- | | |
|----------|---|
| 1 | Remove the main cover of the AC drive and locate the jumper. MR8 only: Push down the grounding arm. See Figure 58. |
|----------|---|

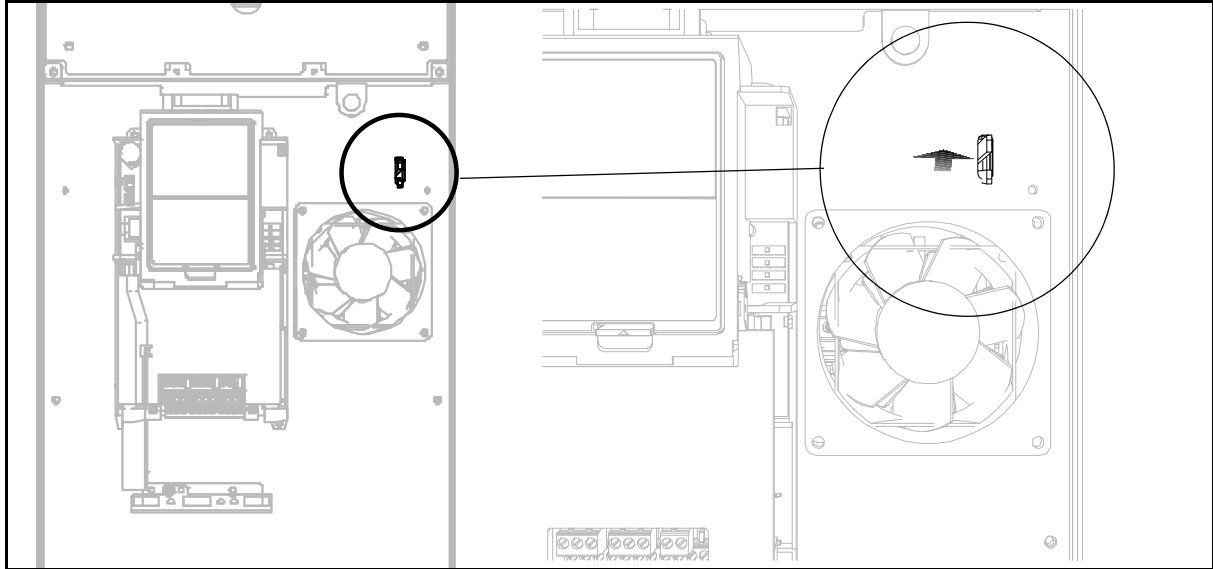

Figure 58.

- | | |
|----------|--|
| 2 | MR7 and MR8: Locate the EMC box under the cover. Remove the screws of the box cover to expose the EMC-jumper. Detach the jumper and re-fix the box cover. |
|----------|--|

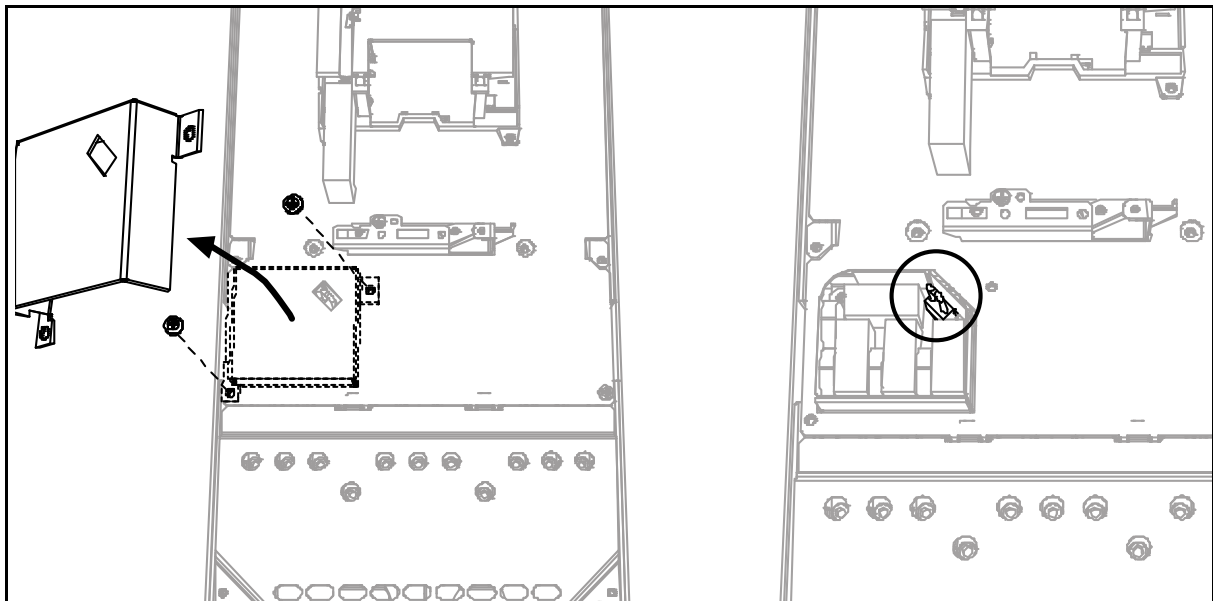

Figure 59.

3 Additionally for MR7, locate the DC grounding busbar between connectors R- and U and detach the busbar from the frame by undoing the M4 screw.

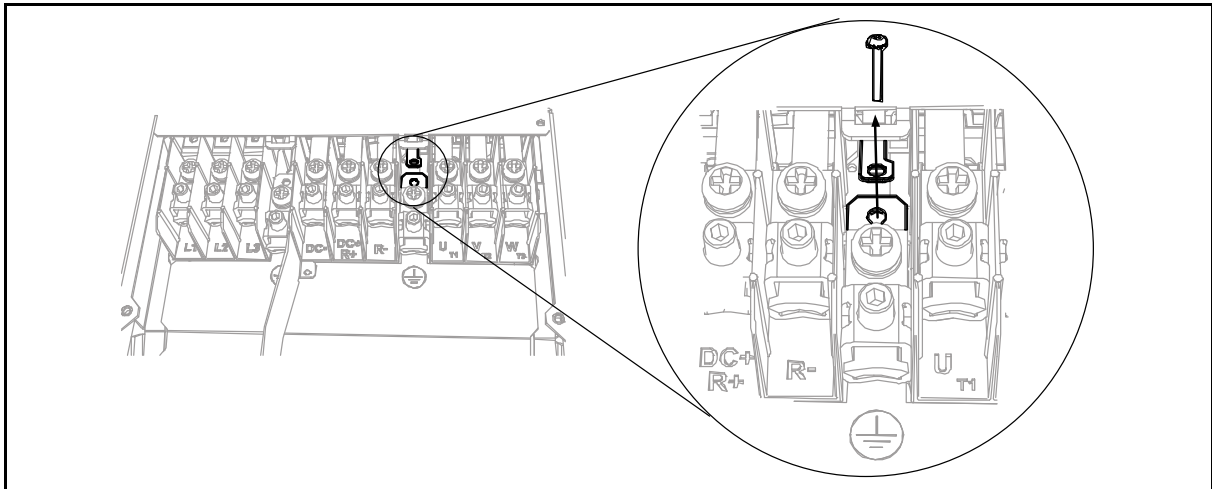

Figure 60. MR7: Detaching the DC grounding busbar from frame

6.3.3 FRAME MR9

Follow the procedure described below to modify the EMC protection of the AC drive of frame MR9 to EMC-level C4.

1 Find the *Molex* connector in the accessories bag. Remove the main cover of the AC drive and locate the place for the connector next to the fan. Push the Molex connector in its place. See Figure 61.

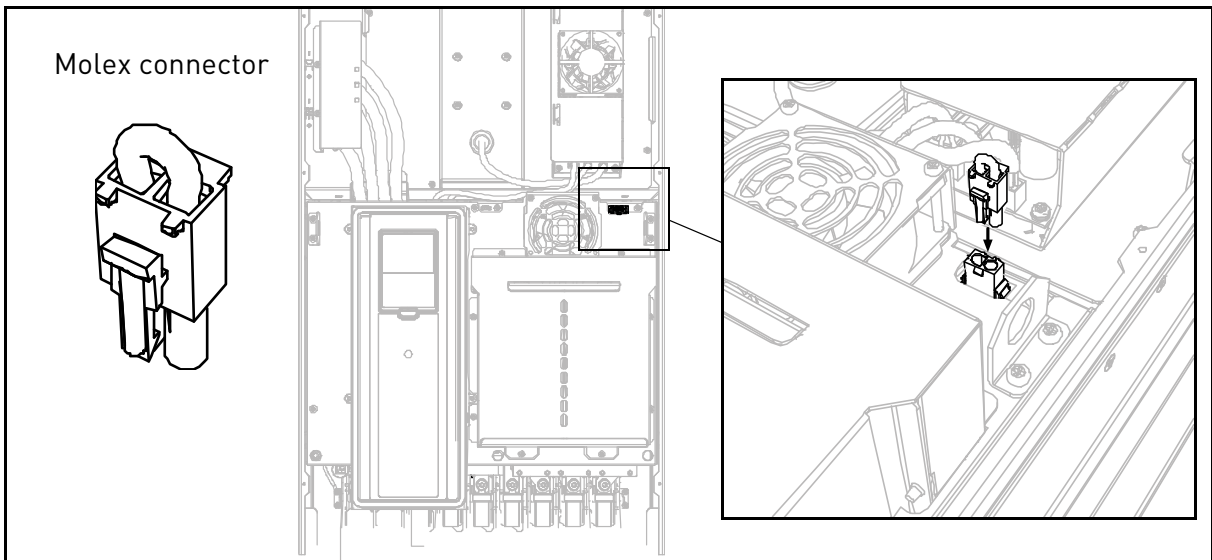

Figure 61.

2	Further remove the extension box cover, the touch shield and the I/O plate with I/O grommet plate. Locate the EMC jumper on the EMC board (see magnification below) and remove it.
----------	--

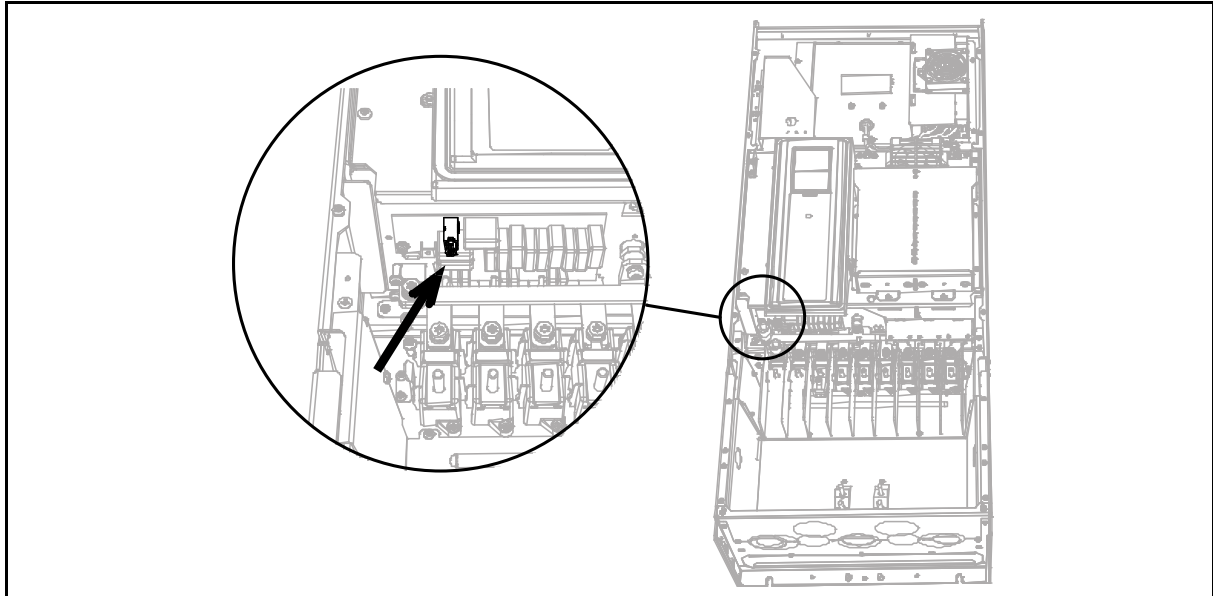

Figure 62.

	CAUTION! Before connecting the AC drive to mains make sure that the EMC protection class settings of the drive are appropriately made.
	NOTE! After having performed the change write 'EMC level modified' on the sticker included in the Vacon 100 delivery (see below) and note the date. Unless already done, attach the sticker close to the name plate of the AC drive.
	<div style="border: 1px solid black; padding: 5px; width: fit-content; margin: 0 auto;"> <p style="text-align: center; margin: 0;">Product modified</p> <p style="text-align: right; margin: 0;">Date:</p> <p style="text-align: right; margin: 0;">Date:</p> <p style="text-align: right; margin: 0;">Date: DDMMYY </p> </div>

6.4 MAINTENANCE

In normal conditions, the AC drive is maintenance-free. However, regular maintenance is recommended to ensure a trouble-free operation and a long lifetime of the drive. We recommend to follow the table below for maintenance intervals.

NOTE: Because of capacitor type (thin film capacitors), reforming of capacitors is not necessary.

Maintenance interval	Maintenance action
Regularly and according to general maintenance interval	<ul style="list-style-type: none"> • Check tightening torques of terminals • Check filters
6...24 months (depending on environment)	<ul style="list-style-type: none"> • Check input and output terminals and control I/O terminals. • Check operation of cooling fan • Check for corrosion on terminals, busbars and other surfaces • Check door filters in case of cabinet installation
24 months	<ul style="list-style-type: none"> • Clean heatsink and cooling tunnel
3...6 years	<ul style="list-style-type: none"> • Change internal IP54 fan
6...10 years	<ul style="list-style-type: none"> • Change main fan

7. TECHNICAL DATA

7.1 AC DRIVE POWER RATINGS

7.1.1 MAINS VOLTAGE 208-240 V

Mains voltage 208-240V, 50-60 Hz, 3~						
Converter type	Loadability			Motor shaft power		
	Low*			230 supply	208-240V supply	
	Rated continuous current I_L [A]	Input current I_{in} [A]	10% overload current [A]	10% overload 40°C [kW]	10% overload 40°C [hp]	
MR4	0003	3.7	3.2	4.1	0.55	0.75
	0004	4.8	4.2	5.3	0.75	1.0
	0006	6.6	6.0	7.3	1.1	1.5
	0008	8.0	7.2	8.8	1.5	2.0
	0011	11.0	9.7	12.1	2.2	3.0
	0012	12.5	10.9	13.8	3.0	4.0
MR5	0018	18.0	16.1	19.8	4.0	5.0
	0024	24.2	21.7	26.4	5.5	7.5
	0031	31.0	27.7	34.1	7.5	10.0
MR6	0048	48.0	43.8	52.8	11.0	15.0
	0062	62.0	57.0	68.2	15.0	20.0
MR7	0075	75.0	69.0	82.5	18.5	25.0
	0088	88.0	82.1	96.8	22.0	30.0
	0105	105.0	99.0	115.5	30.0	40.0
MR8	0140	143.0	135.1	154.0	37.0	50.0
	0170	170.0	162.0	187.0	45.0	60.0
	0205	208.0	200.0	225.5	55.0	75.0
MR9	0261	261.0	253.0	287.1	75.0	100.0
	0310	310.0	301.0	341.0	90.0	125.0

* See chapter 7.1.3.

Table 29. Power ratings of Vacon 100, supply voltage 208-240V.

NOTE: The rated currents in given ambient temperatures (in Table 31) are achieved only when the switching frequency is equal to or less than the factory default.

7.1.2 MAINS VOLTAGE 380-480 V

Mains voltage 380-480V, 50-60 Hz, 3~						
Converter type	Loadability			Motor shaft power		
	Low*			400V supply	480V supply	
	Rated continuous current I _L [A]	Input current I _{in} [A]	10% overload current [A]	10% overload 40°C [kW]	10% overload 40°C [HP]	
MR4	0003	3.4	3.4	3.7	1.1	1.5
	0004	4.8	4.6	5.3	1.5	2.0
	0005	5.6	5.4	6.2	2.2	3.0
	0008	8.0	8.1	8.8	3.0	5.0
	0009	9.6	9.3	10.6	4.0	5.0
	0012	12.0	11.3	13.2	5.5	7.5
MR5	0016	16.0	15.4	17.6	7.5	10
	0023	23.0	21.3	25.3	11.0	15.0
	0031	31.0	28.4	34.1	15.0	20.0
MR6	0038	38.0	36.7	41.8	18.5	25.0
	0046	46.0	43.6	50.6	22.0	30.0
	0061	61.0	58.2	67.1	30.0	40.0
MR7	0072	72.0	67.5	79.2	37.0	50.0
	0087	87.0	85.3	95.7	45.0	60.0
	0105	105.0	100.6	115.5	55.0	75.0
MR8	0140	140.0	139.4	154.0	75.0	100.0
	0170	170.0	166.5	187.0	90.0	125.0
	0205	205.0	199.6	225.5	110.0	150.0
MR9	0261	261.0	258.0	287.1	132.0	200.0
	0310	310.0	303.0	341.0	160.0	250.0

* See chapter 7.1.3

Table 30. Power ratings of Vacon 100, supply voltage 380-480V.

NOTE: The rated currents in given ambient temperatures (in Table 31) are achieved only when the switching frequency is equal to or less than the factory default.

7.1.3 DEFINITIONS OF OVERLOADABILITY

Low overload = Following continuous operation at rated output current I_L , the converter is fed with $110\% * I_L$ for 1 min, followed by a period of I_L .

Example: If the duty cycle requires 110% rated current I_L for 1 min in every 10 min, the remaining 9 min must be at rated current or less.

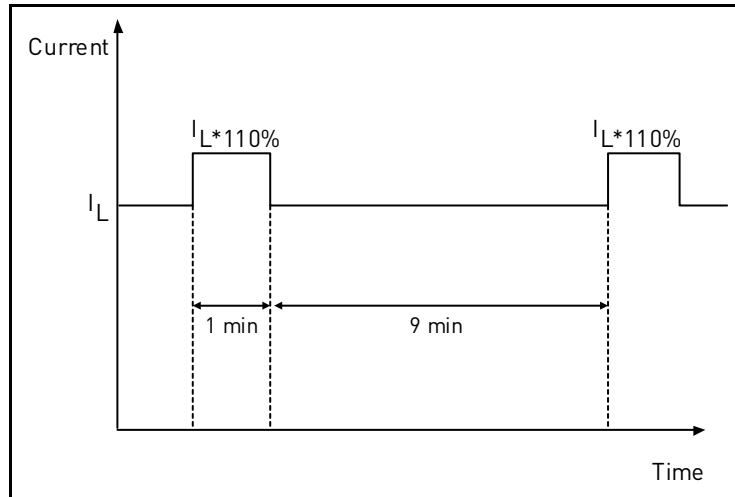

Figure 63. Low overload

7.2 VACON 100 - TECHNICAL DATA

Mains connection	Input voltage U_{in}	208...240V; 380...480V; -10%...+10%
	Input frequency	50...60 Hz -5...+10%
	Connection to mains	Once per minute or less
	Starting delay	4 s (MR4 to MR6); 6 s (MR7 to MR9)
Motor connection	Output voltage	$0-U_{in}$
	Continuous output current	I_L : Ambient temperature max. +40°C, up to +50°C with derating; overload 1.1 x I_L (1 min./10 min.)
	Output frequency	0...320 Hz (standard)
	Frequency resolution	0.01 Hz
Control characteristics	Switching frequency (see parameter P3.1.2.1)	1.5...10 kHz; Defaults: MR4-6: 6 kHz (except 0012 2, 0031 2, 0062 2, 0012 4, 0031 4 and 0061 4: 4 kHz) MR7: 4 kHz MR8-9: 3 kHz Automatic switching frequency derating in case of overload.
	Frequency reference Analogue input Panel reference	Resolution 0.1% (10-bit), accuracy ±1% Resolution 0.01 Hz
	Field weakening point	8...320 Hz
	Acceleration time	0.1...3000 sec
	Deceleration time	0.1...3000 sec
	Ambient operating temperature	I_L : -10°C (no frost)...+40°C; up to +50°C with derating
Storage temperature	-40°C...+70°C	
Relative humidity	0...95% R_H , non-condensing, non-corrosive	
Ambient conditions	Air quality: • chemical vapours • mechanical particles	Tested according to IEC 60068-2-60 Test Ke: Flowing mixed gas corrosion test, Method 1 (H ₂ S [hydrogen sulfide] and SO ₂ [sulfur dioxide]) Designed according to: IEC 60721-3-3, unit in operation, class 3C2 IEC 60721-3-3, unit in operation, class 3S2
	Altitude	100% load capacity (no derating) up to 1,000m 1-% derating for each 100m above 1,000m <u>Max. altitudes:</u> 208...240V: 4,500m (TN and IT systems) 380...480V: 4,500m (TN and IT systems) <u>Voltage for I/O signals:</u> Up to 2,000m : Allowed up to 240V 2,000m...4,500m: Allowed up to 120V Corner-grounding: up to 2,000m only.

Ambient conditions (cont.)	Vibration EN61800-5-1/ EN60068-2-6	5...150 Hz Displacement amplitude 1 mm (peak) at 5...15.8 Hz (MR4...MR9) Max acceleration amplitude 1 G at 15.8...150 Hz (MR4...MR9)
	Shock EN61800-5-1 EN60068-2-27	UPS Drop Test (for applicable UPS weights) Storage and shipping: max 15 G, 11 ms (in package)
	Enclosure class	IP21/Type 1 standard in entire kW/HP range IP54/Type 12 option Note! Keypad required for IP54/Type 12
EMC (at default settings)	Immunity	Fulfills EN61800-3 (2004), first and second environment
	Emissions	+EMC2: EN61800-3 (2004), Category C2 The drive can be modified for IT-networks. See chapter 6.3 on page 65.
Noise level	Average noise level (cooling fan) sound power level in dB(A)	MR4: 65 MR7: 77 MR5: 70 MR8: 86 MR6: 77 MR9: 87
Safety		EN 61800-5-1 (2007), CE, cUL; (see unit nameplate for more detailed approvals)
Protections	Overvoltage trip limit	240-volt drives: 456 V 480-volt drives: 911 V
	Undervoltage trip limit	Depends on supply voltage (0,8775*supply voltage): Supply voltage 240 V: Trip limit 211 V Supply voltage 400 V: Trip limit 351 V Supply voltage 480 V: Trip limit 421 V
	Earth fault protection	Yes
	Mains supervision	Yes
	Motor phase supervision	Yes
	Overcurrent protection	Yes
	Unit overtemperature protection	Yes
	Motor overload protection	Yes
	Motor stall protection	Yes
	Motor underload protection	Yes
Short-circuit protection of +24V and +10V reference voltages	Yes	

Table 31. Vacon 100 technical data

7.2.1 TECHNICAL INFORMATION ON CONTROL CONNECTIONS

Standard I/O board		
Terminal	Signal	Technical information
1	Reference output	+10V, +3%; Maximum current 10 mA
2	Analogue input, voltage or current	Analogue input channel 1 0- +10V (Ri = 200 k Ω) 4-20 mA (Ri =250 Ω) Resolution 0.1 %, accuracy ± 1 % Selection V/mA with dip-switches (see page 52) Short-circuited protected.
3	Analogue input common (current)	Differential input if not connected to ground; Allows ± 20 V differential mode voltage to GND
4	Analogue input, voltage or current	Analogue input channel 2 Default: 4-20 mA (Ri =250 Ω) 0-10 V (Ri=200k Ω) Resolution 0.1 %, accuracy ± 1 % Selection V/mA with dip-switches (see page 52) Short-circuited protected.
5	Analogue input common (current)	Differential input if not connected to ground; Allows 20V differential mode voltage to GND
6	24V aux. voltage	+24V, $\pm 10\%$, max volt. ripple < 100mVrms; max. 250mA Dimensioning: max. 1000mA/control unit. Short-circuit protected.
7	I/O ground	Ground for reference and controls (connected internally to frame earth through 1M Ω)
8	Digital input 1	Positive or negative logic Ri = min. 5k Ω 0...5V = "0" 15...30V = "1"
9	Digital input 2	
10	Digital input 3	
11	Common A for DIN1-DIN6	Digital inputs can be disconnected from ground, see chapter 5.1.2.2.
12	24V aux. voltage	+24V, $\pm 10\%$, max volt. ripple < 100mVrms; max. 250mA Dimensioning: max. 1000mA/control unit. Short-circuit protected
13	I/O ground	Ground for reference and controls (connected internally to frame earth through 1M Ω)
14	Digital input 4	Positive or negative logic Ri = min. 5k Ω 0...5V = "0" 15...30V = "1"
15	Digital input 5	
16	Digital input 6	
17	Common A for DIN1-DIN6	Digital inputs can be isolated from ground, see chapter 5.1.2.2.
18	Analogue signal (+output)	Analogue output channel 1, selection 0 -20mA, load <500 Ω Default: 0-20 mA 0-10V Resolution 0.1 %, accuracy ± 2 % Selection V/mA with dip-switches (see page 52) Short-circuited protected.
19	Analogue output common	
30	24V auxiliary input voltage	Can be used as external power backup for the control unit.
A	RS485	Differential receiver/transmitter Set bus termination with dip switches (see page 52)
B	RS485	

Table 32. Technical information on standard I/O board

Relay board 1		Relay board with two change-over contact (SPDT) relays and one relay with normally-open (NO or SPST) contact. 5,5 mm isolation between channels.	
Terminal	Signal	Technical information	
21	Relay output 1*	Switching capacity	24VDC/8A
22			250VAC/8A
23		Min.switching load	125VDC/0.4A
24	Relay output 2*	Min.switching load	5V/10mA
25		Switching capacity	24VDC/8A
26			250VAC/8A
32	Relay output 3*		125VDC/0.4A
33		Switching capacity	24VDC/8A
			250VAC/8A
		Min.switching load	5V/10mA

* If 230VAC is used as control voltage from the output relays, the control circuitry must be powered with a separate isolation transformer to limit short circuit current and overvoltage spikes. This is to prevent welding on the relay contacts. Refer to standard EN 60204-1, section 7.2.9

Table 33. Technical information on Relay board 1

Relay board 2		Relay board with two change-over contact (SPDT) relays and a PTC thermistor input. 5,5 mm isolation between channels.	
Terminal	Signal	Technical information	
21	Relay output 1*	Switching capacity	24VDC/8A
22			250VAC/8A
23		Min.switching load	125VDC/0.4A
24	Relay output 2*	Min.switching load	5V/10mA
25		Switching capacity	24VDC/8A
26			250VAC/8A
28	Thermistor input		125VDC/0.4A
29			5V/10mA
		Rtrip = 4.7 kΩ (PTC); Measuring voltage 3.5V	

* If 230VAC is used as control voltage from the output relays, the control circuitry must be powered with a separate isolation transformer to limit short circuit current and overvoltage spikes. This is to prevent welding on the relay contacts. Refer to standard EN 60204-1, section 7.2.9

Table 34. Technical information on Relay board 2

VACON

DRIVEN BY DRIVES

Find your nearest Vacon office
on the Internet at:

www.vacon.com



Manual authoring:
documentation@vacon.com

Vacon Plc.
Runsorintie 7
65380 Vaasa
Finland

Subject to change without prior notice
© 2011 Vacon Plc.

Document ID:



Order code:



Rev. D